

Figure 1
 X-Cell Gas Graphite
<http://www.rchelibase.com>

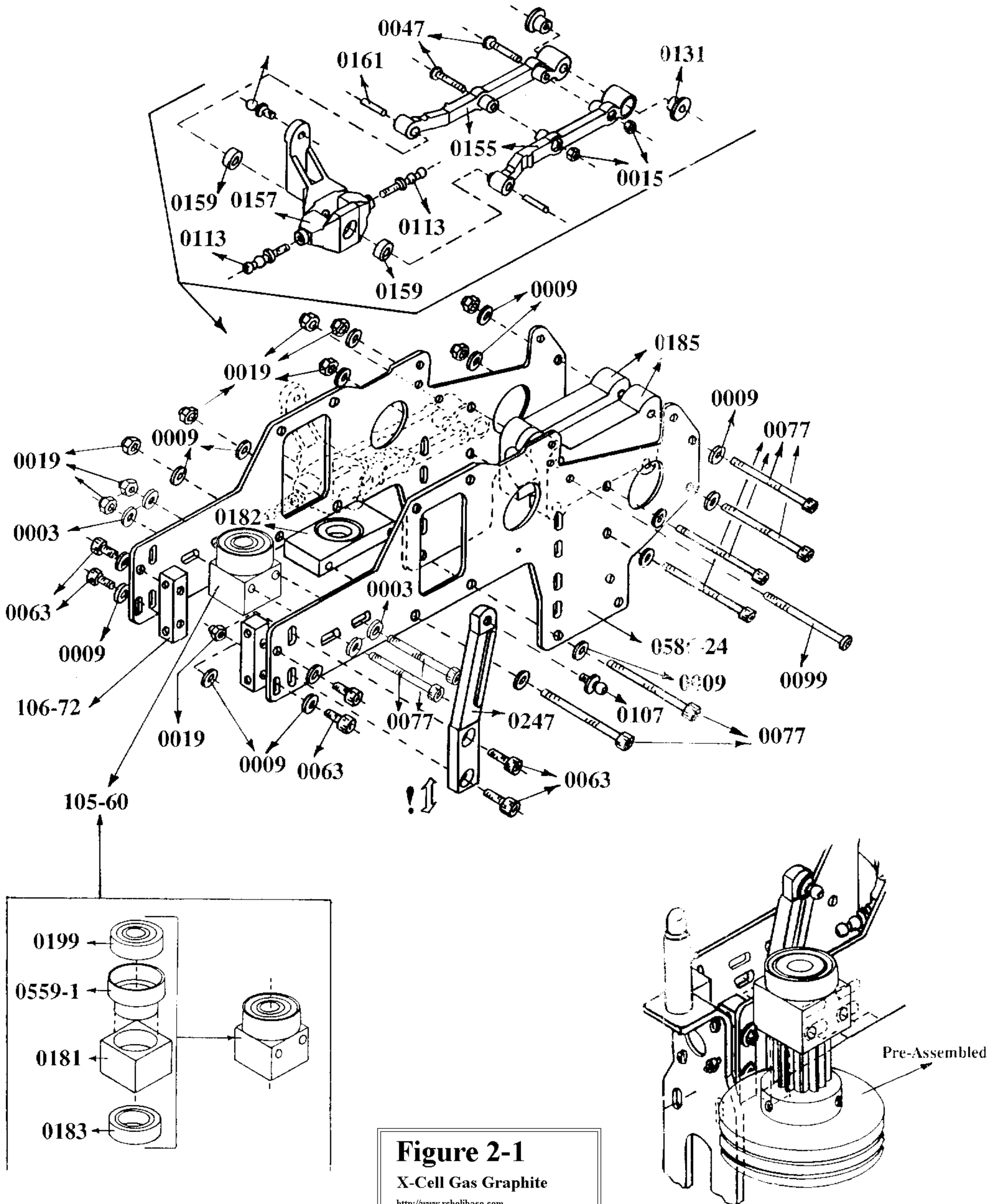

Figure 2-1

X-Cell Gas Graphite

<http://www.rchelibase.com>

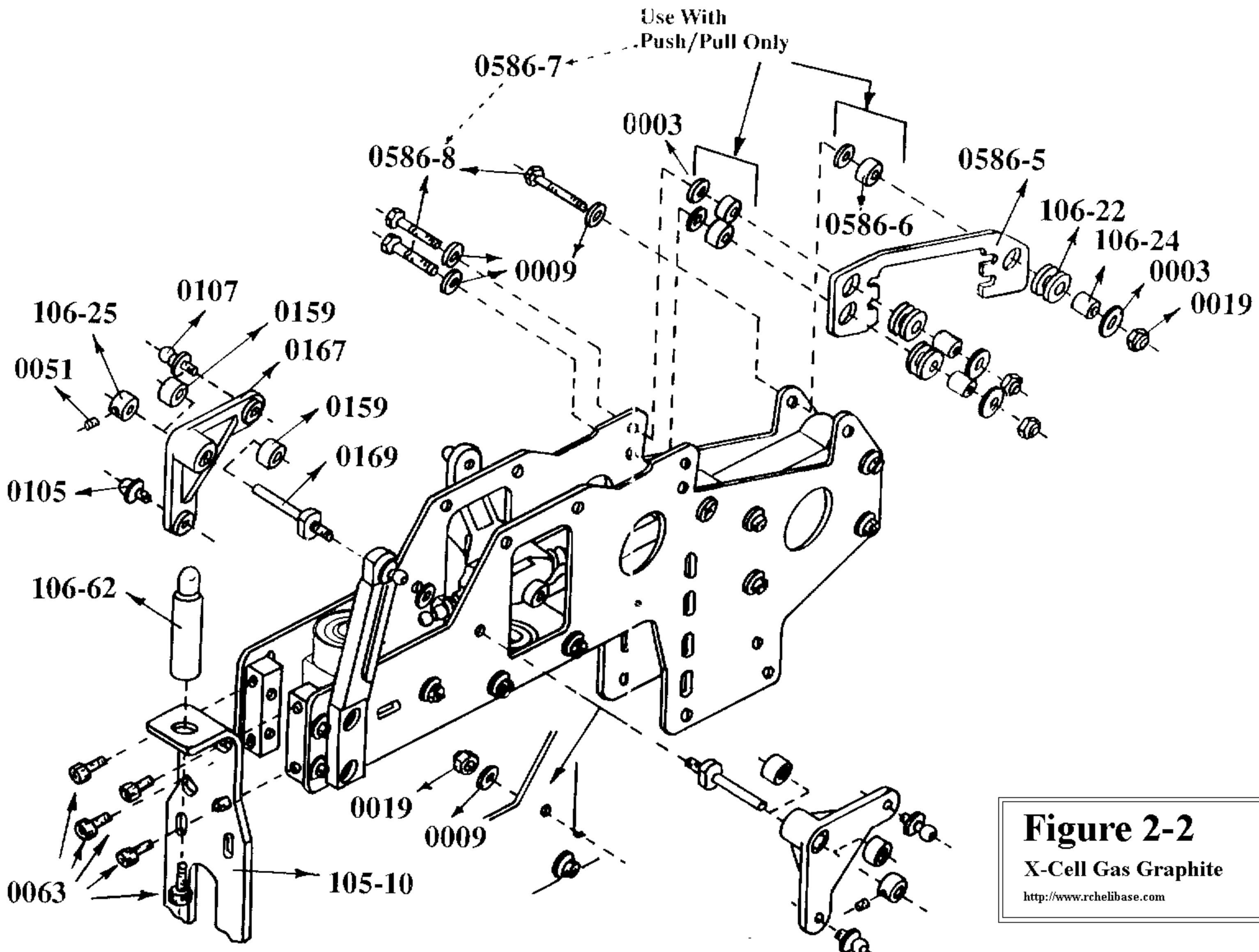
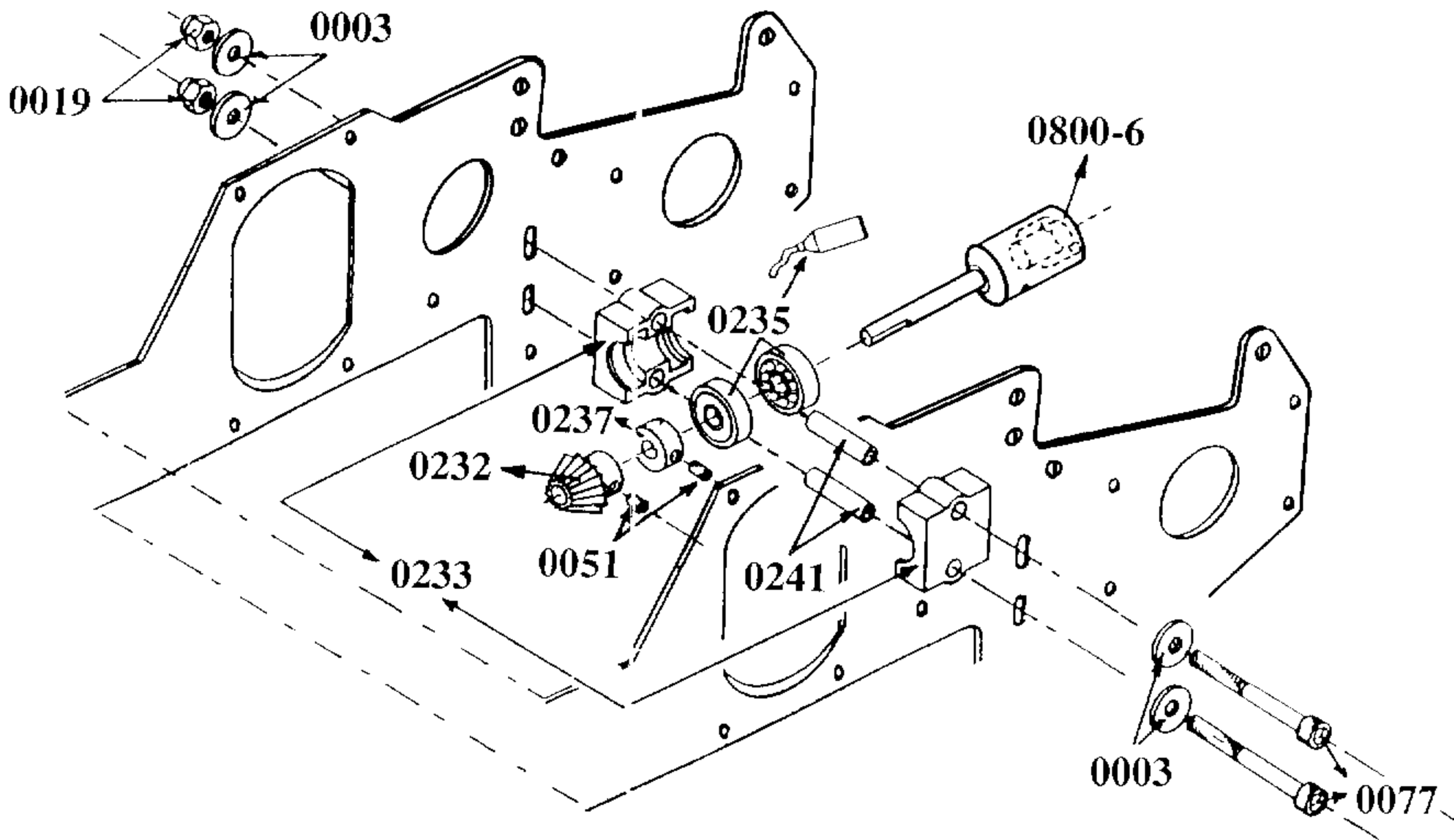

Figure 2-2
 X-Cell Gas Graphite
<http://www.rchelibase.com>

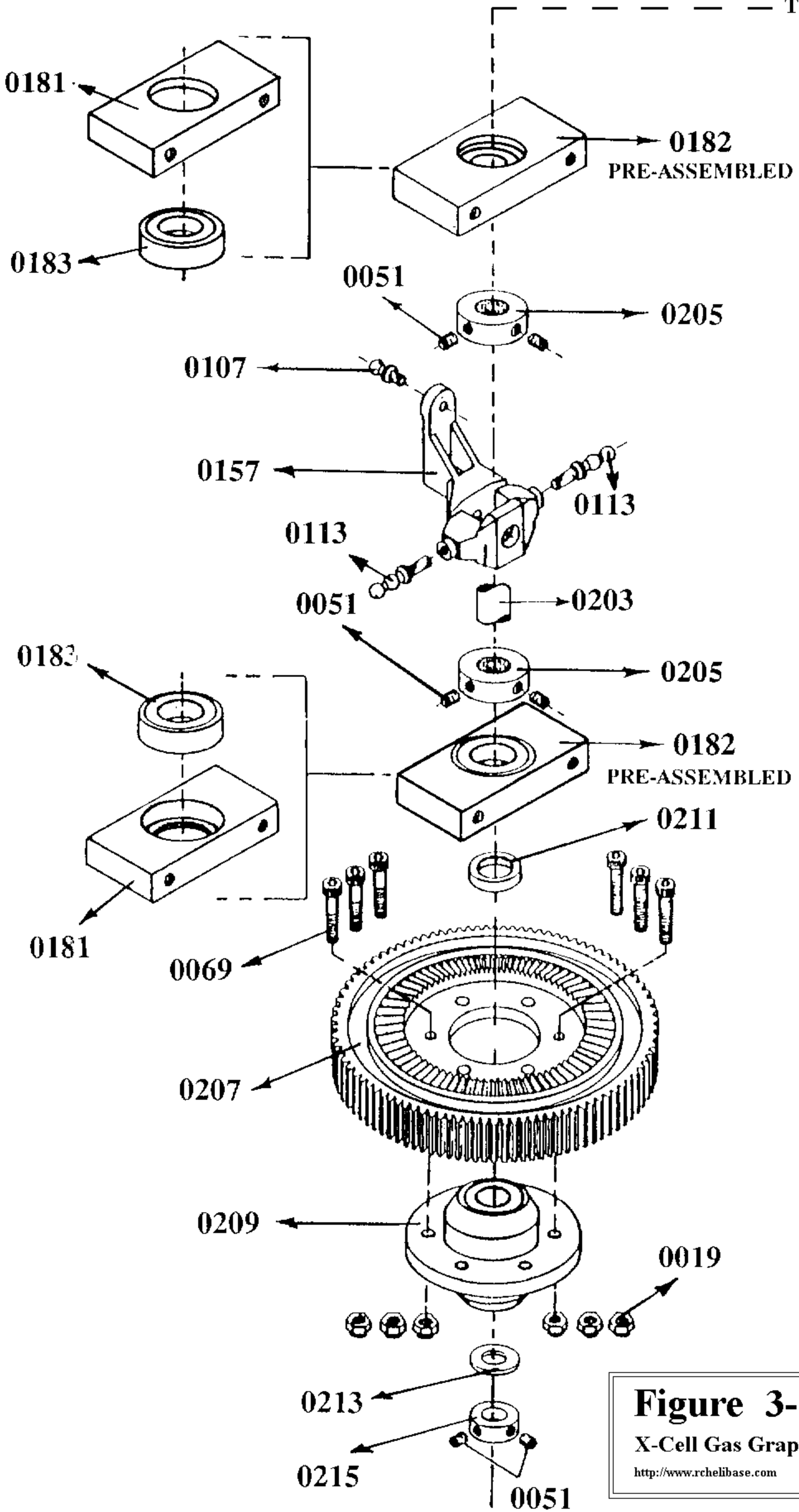

Figure 3-1
X-Cell Gas Graphite
<http://www.rchelibase.com>

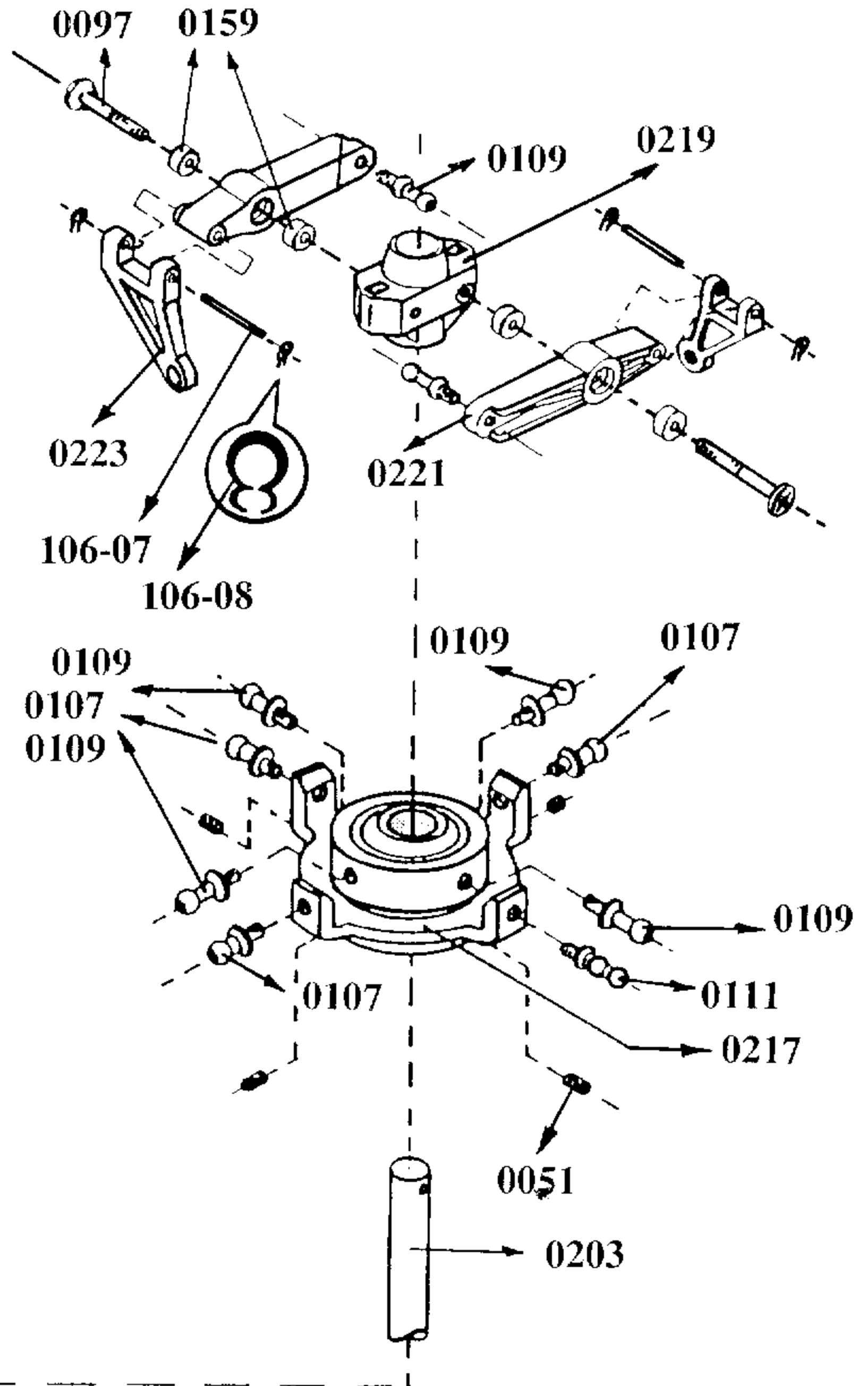
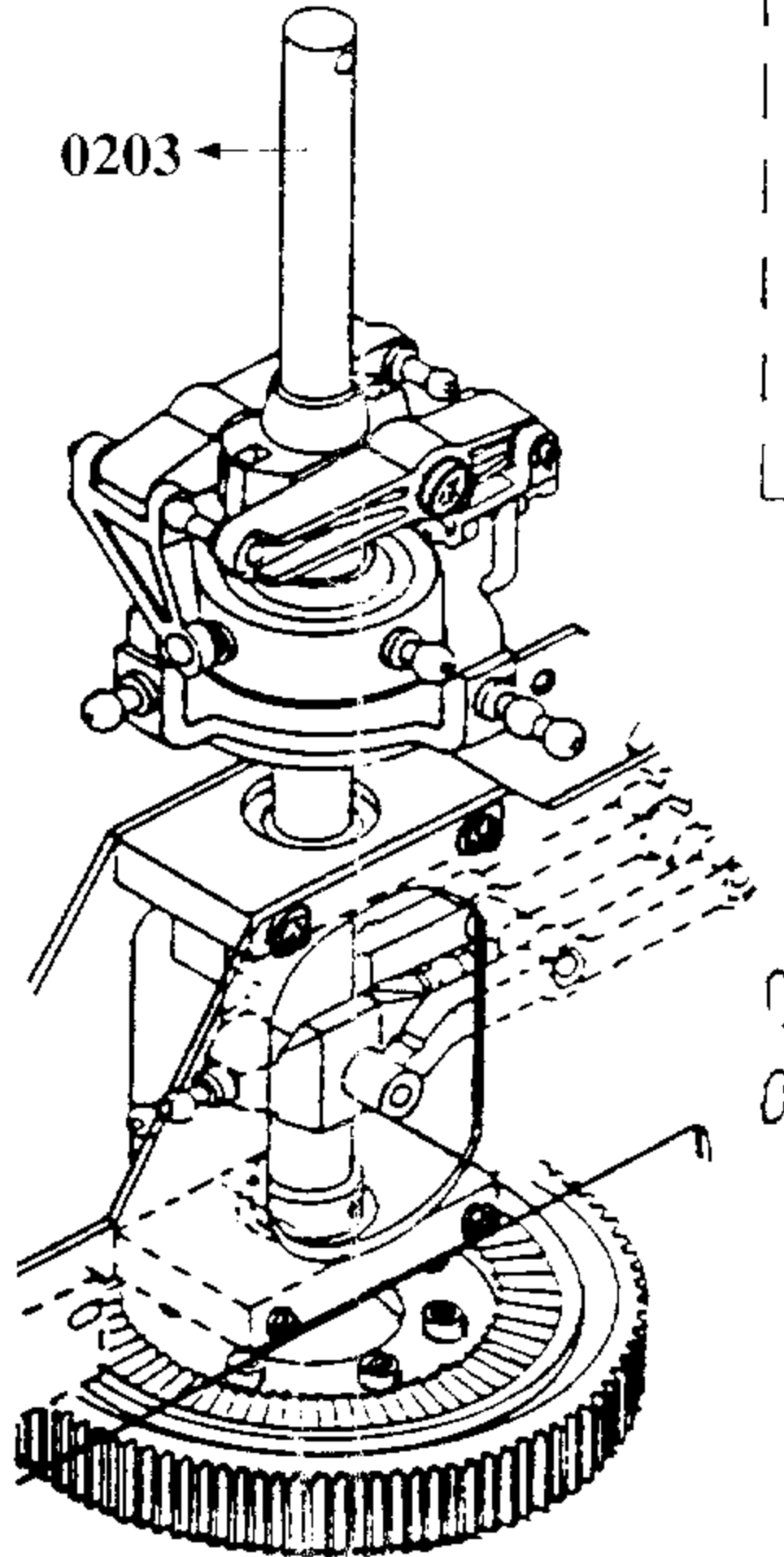

Figure 3-2
X-Cell Gas Graphite
<http://www.rchelibase.com>

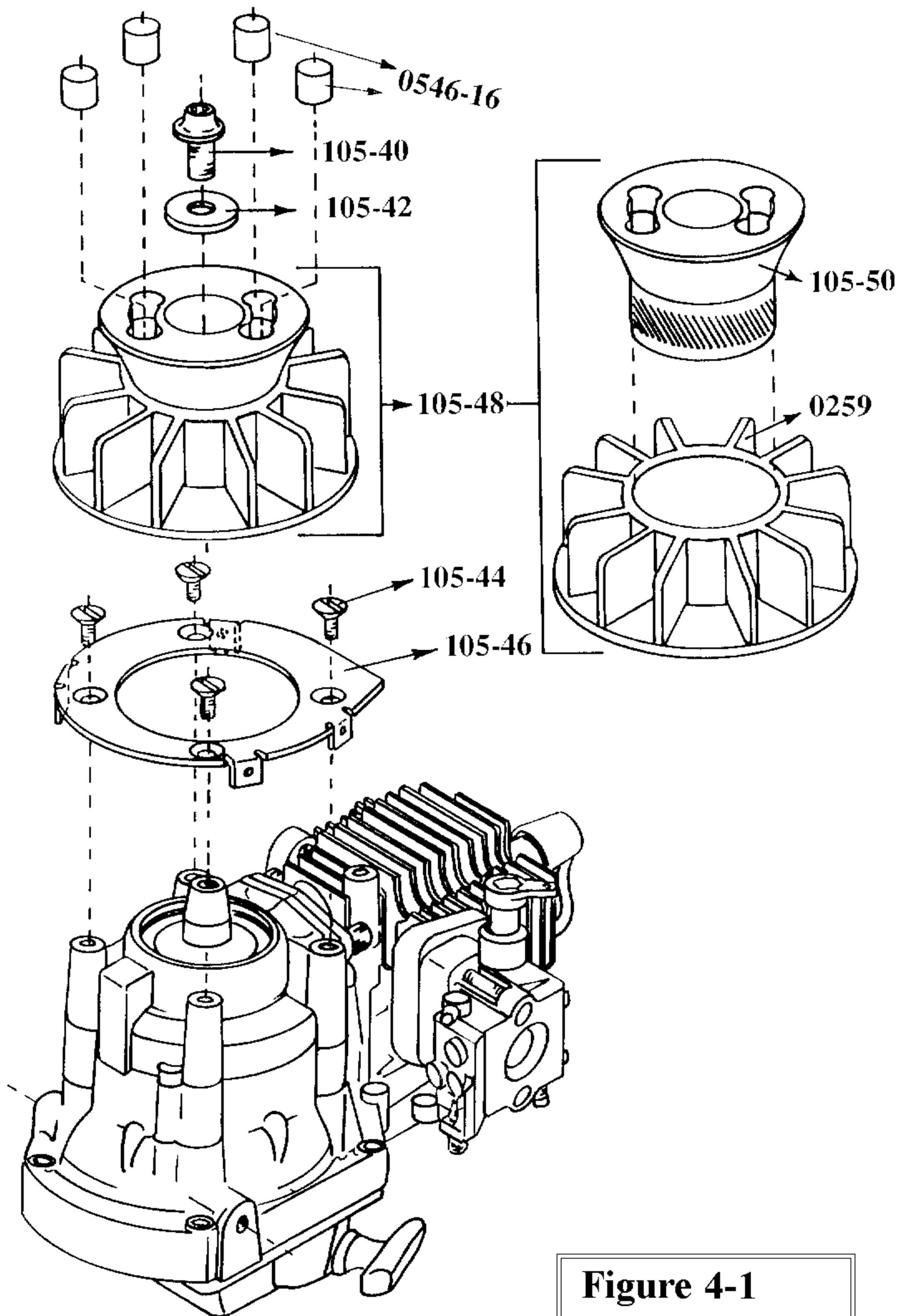

Figure 4-1

X-Cell Gas Graphite

<http://www.rchelibase.com>

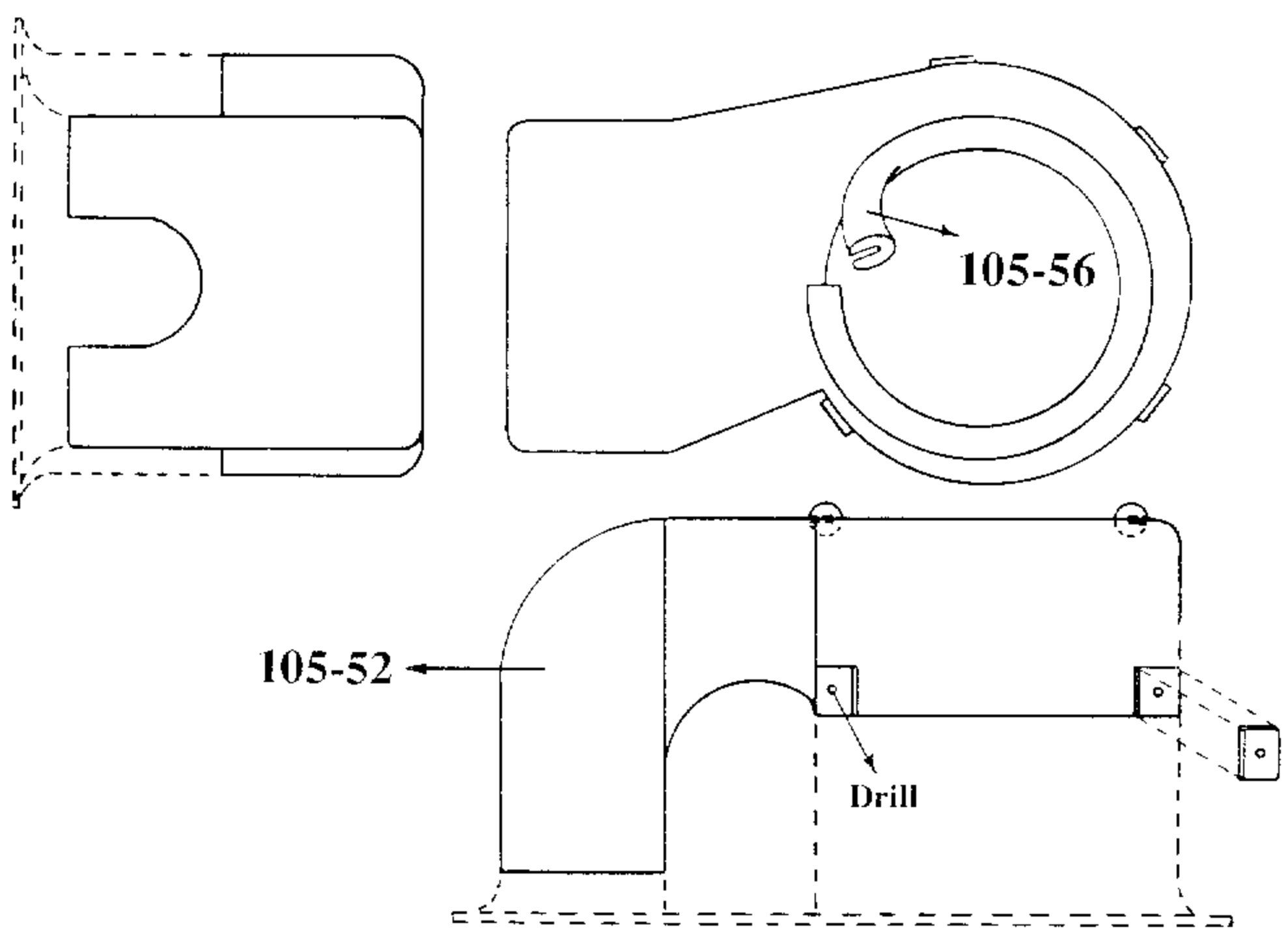
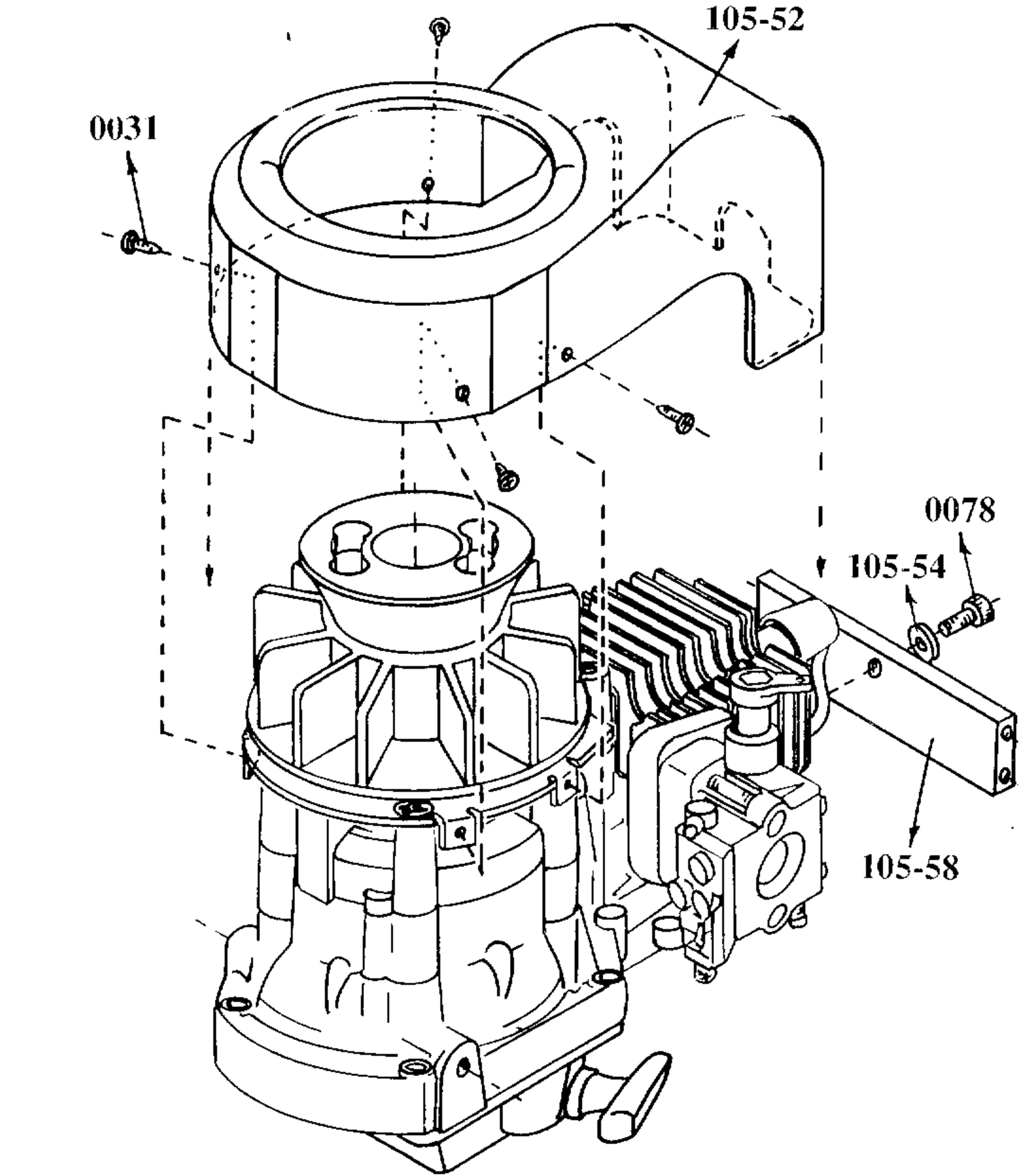

Figure 4-2
X-Cell Gas Graphite
<http://www.rchelibase.com>

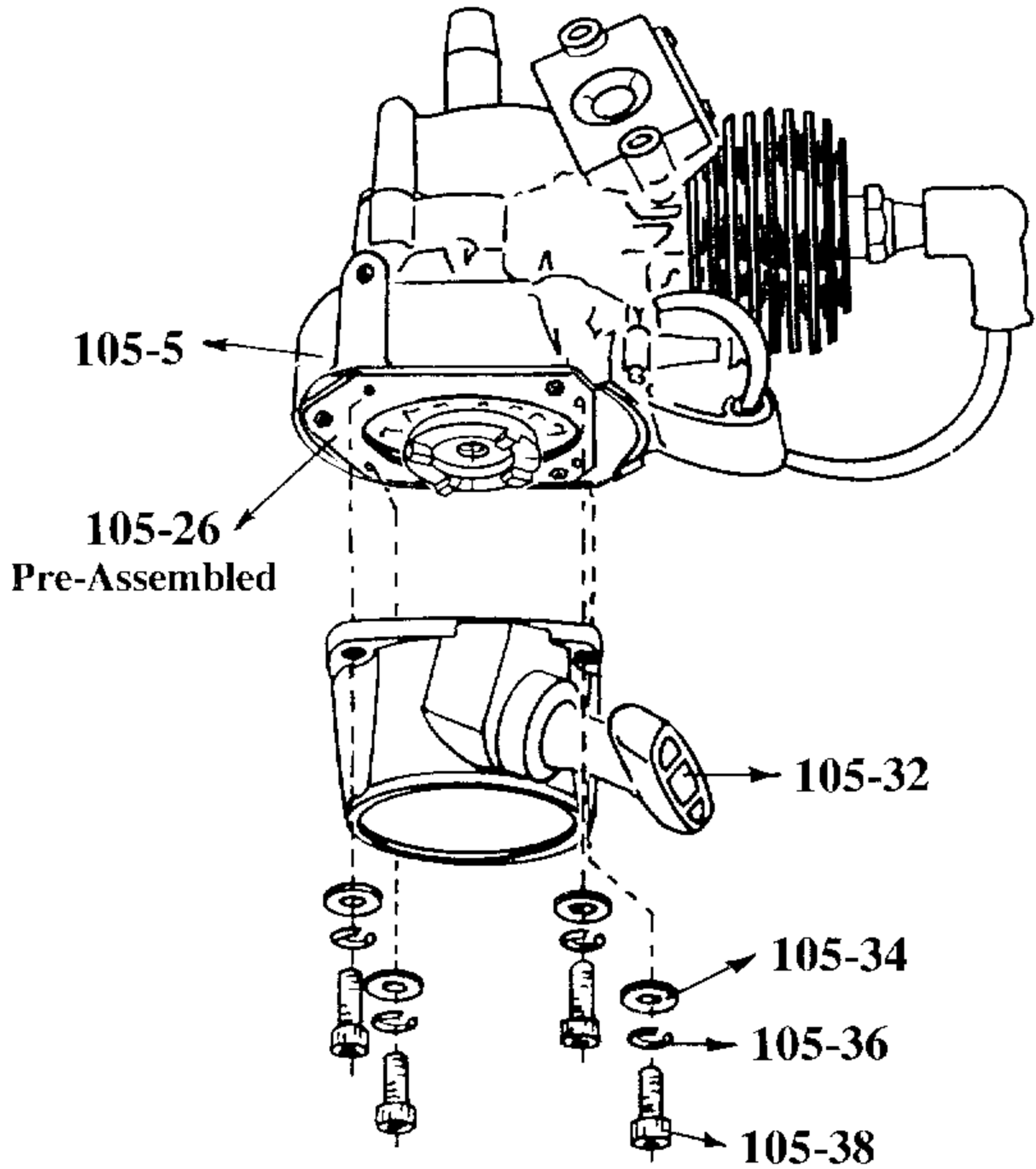

Figure 4-3
X-Cell Gas Graphite
<http://www.rchelibase.com>

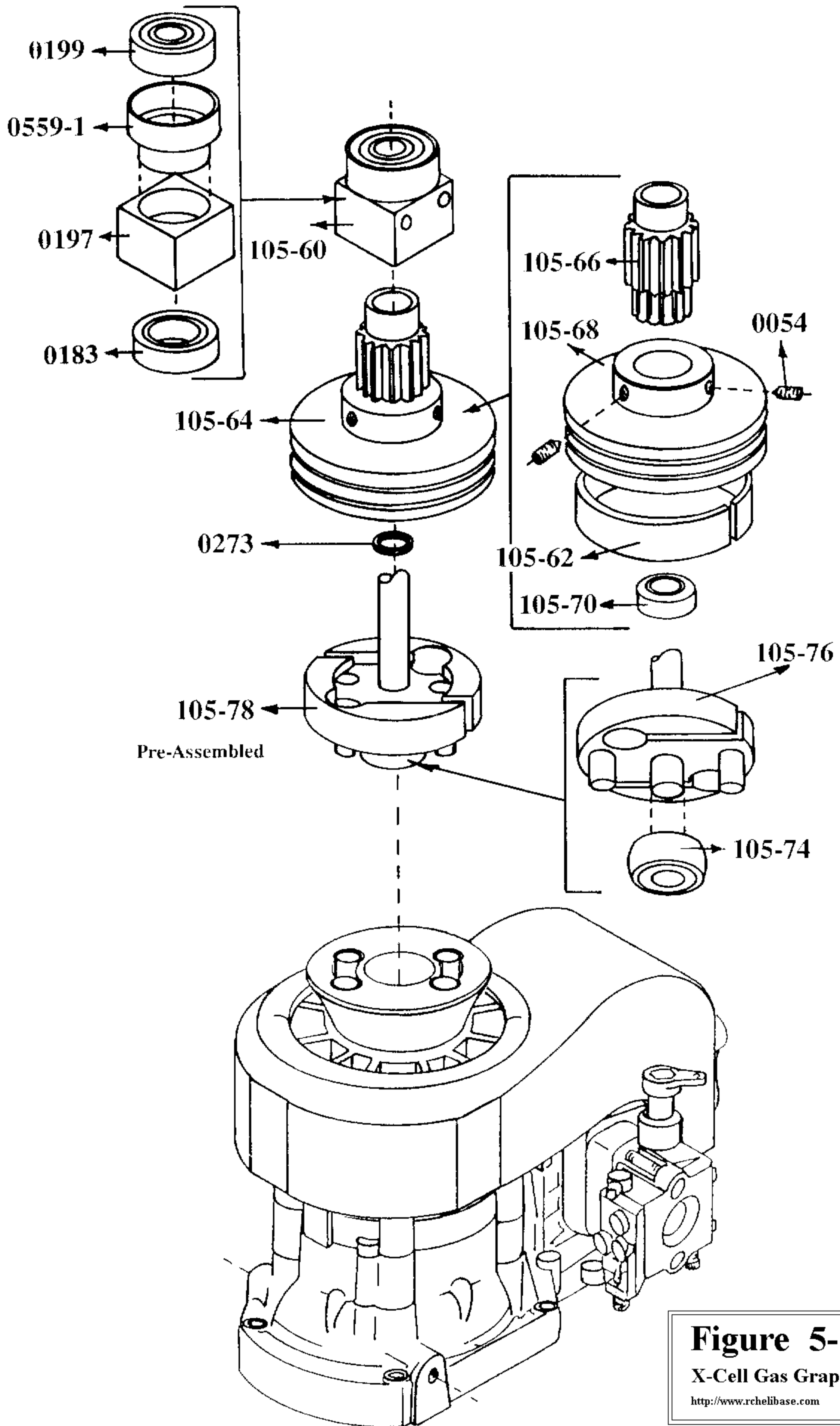

Figure 5-1
 X-Cell Gas Graphite
<http://www.rchelibase.com>

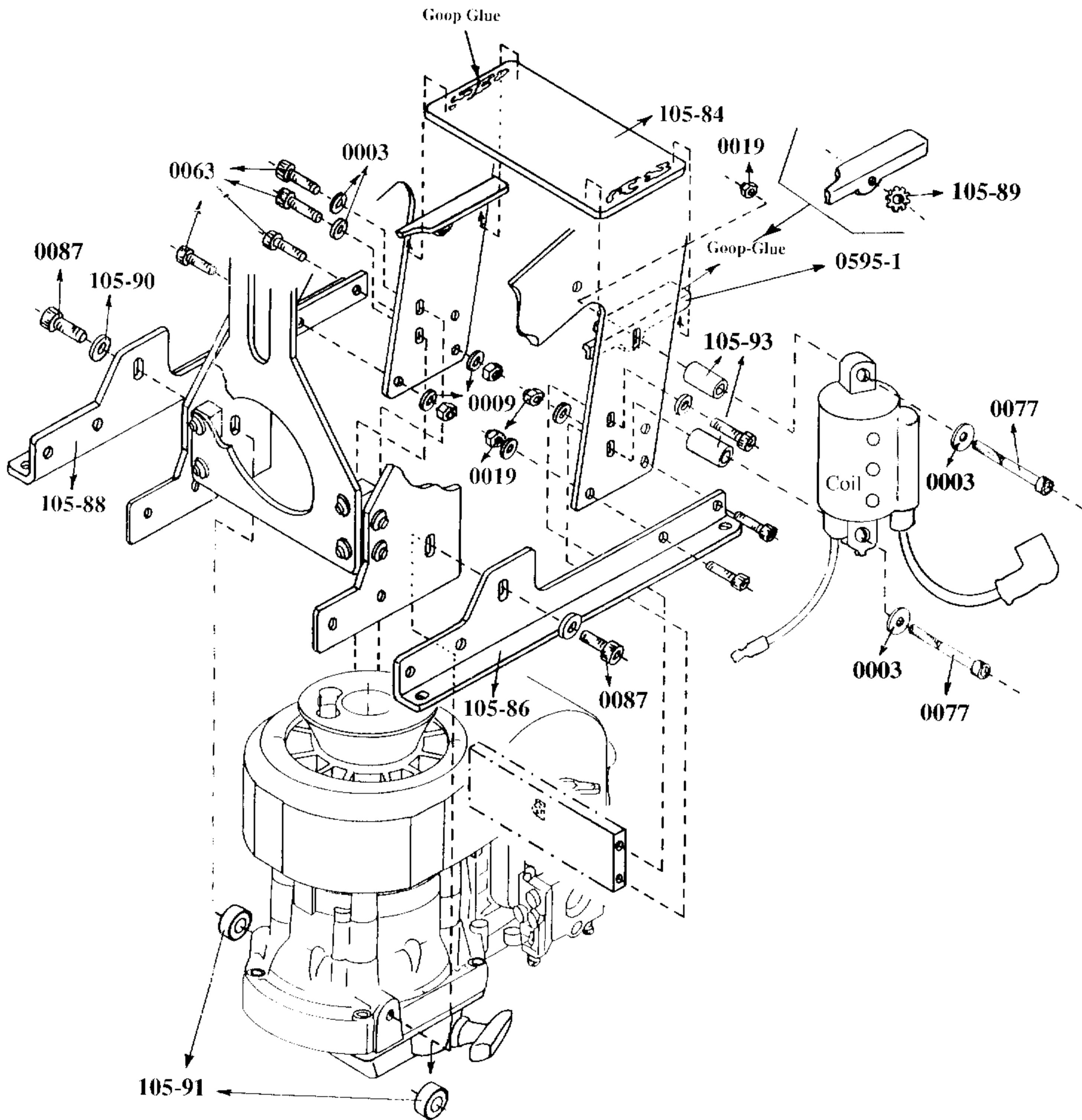

Figure 5-2
X-Cell Gas Graphite
<http://www.rchelibase.com>

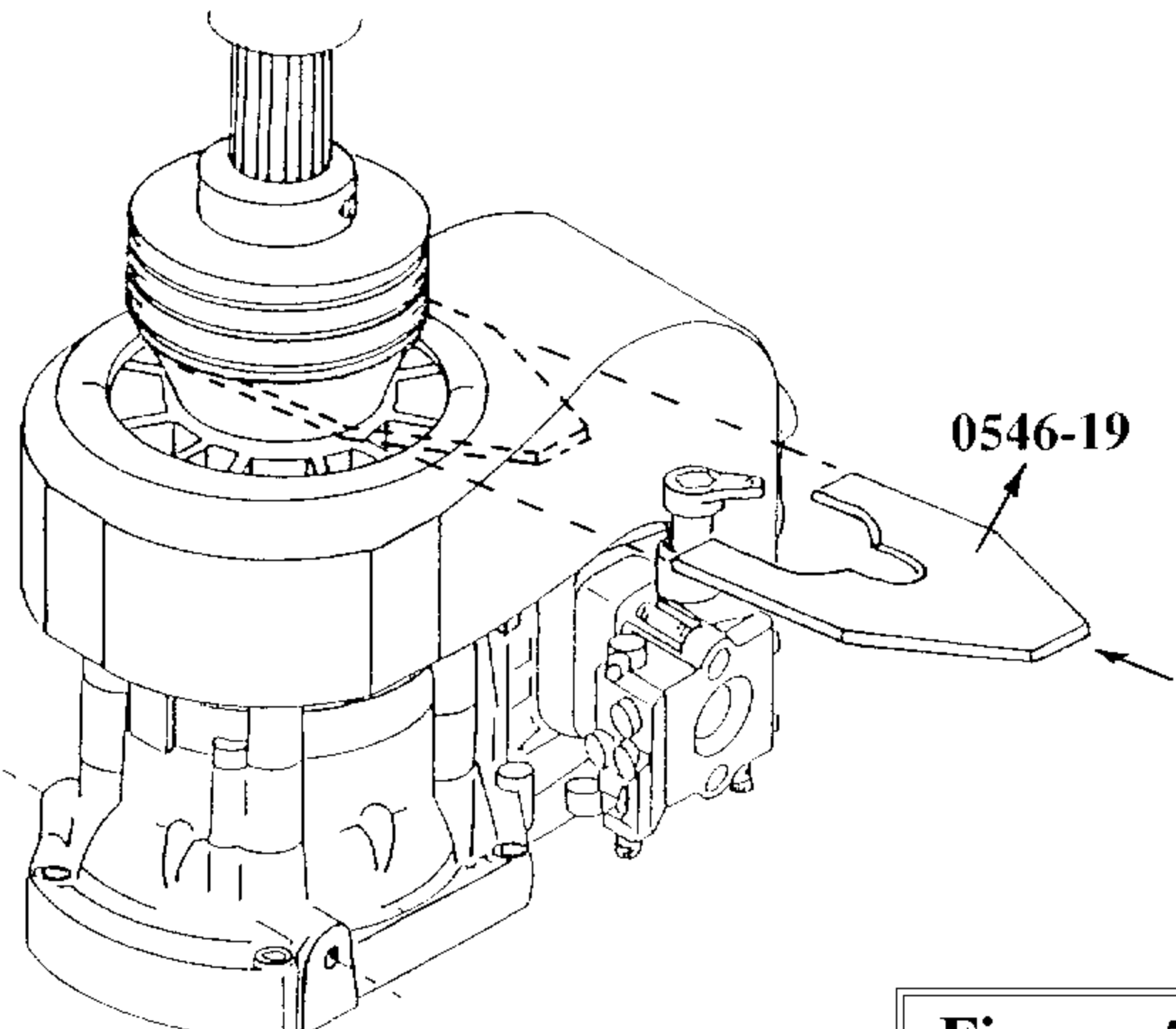
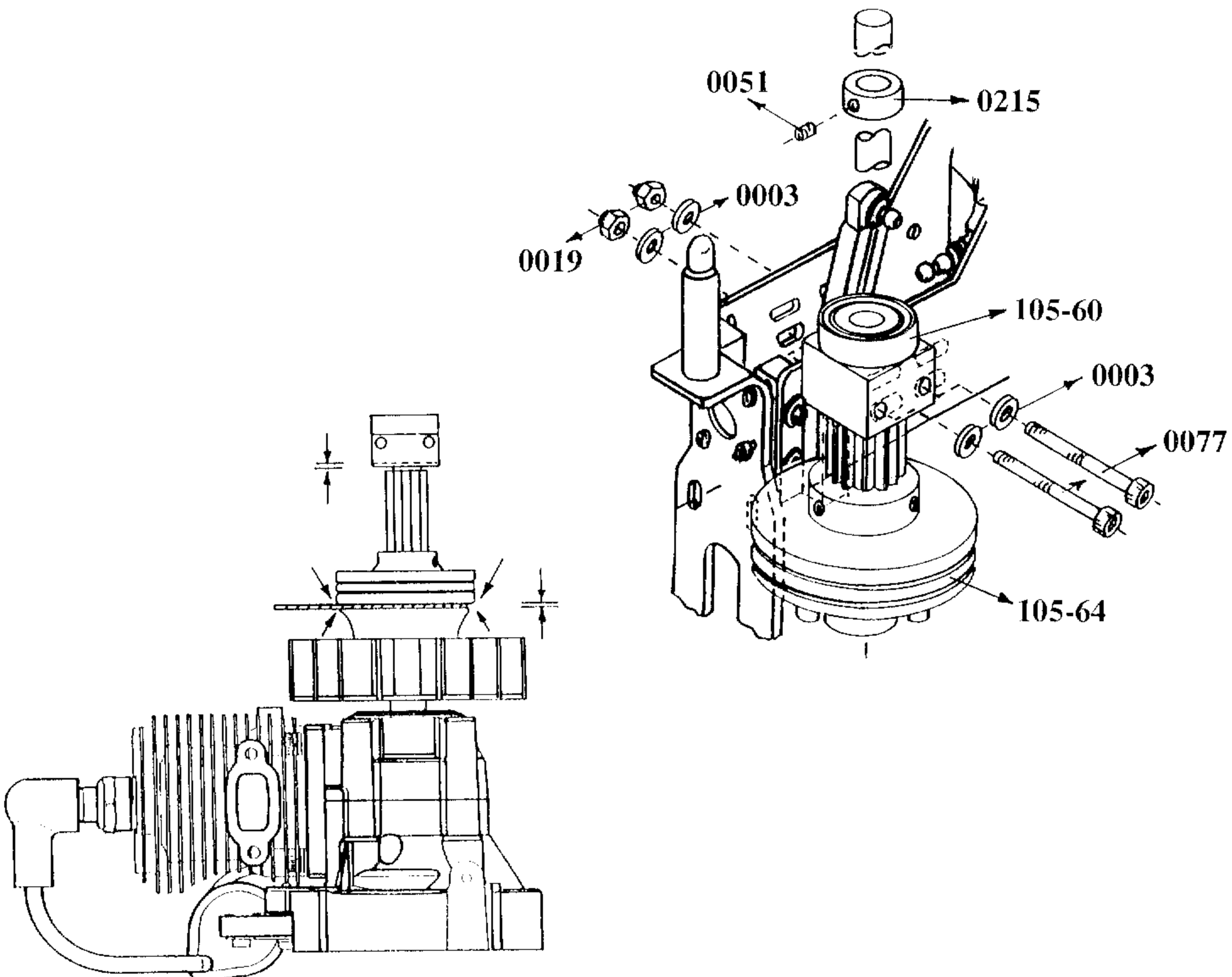

Figure 5-3
 X-Cell Gas Graphite
<http://www.rchelibase.com>

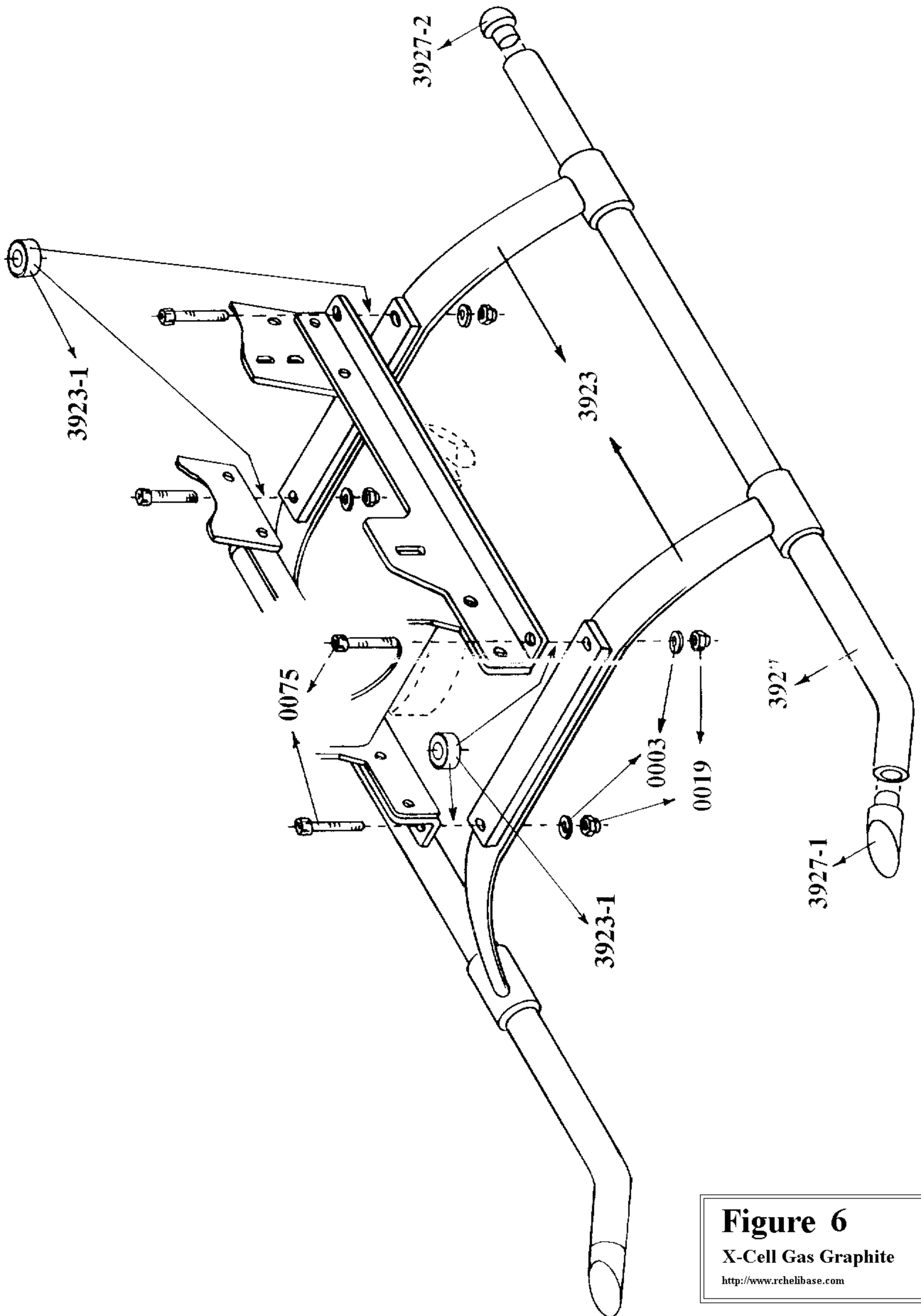

Figure 6
 X-Cell Gas Graphite
<http://www.rchelibase.com>

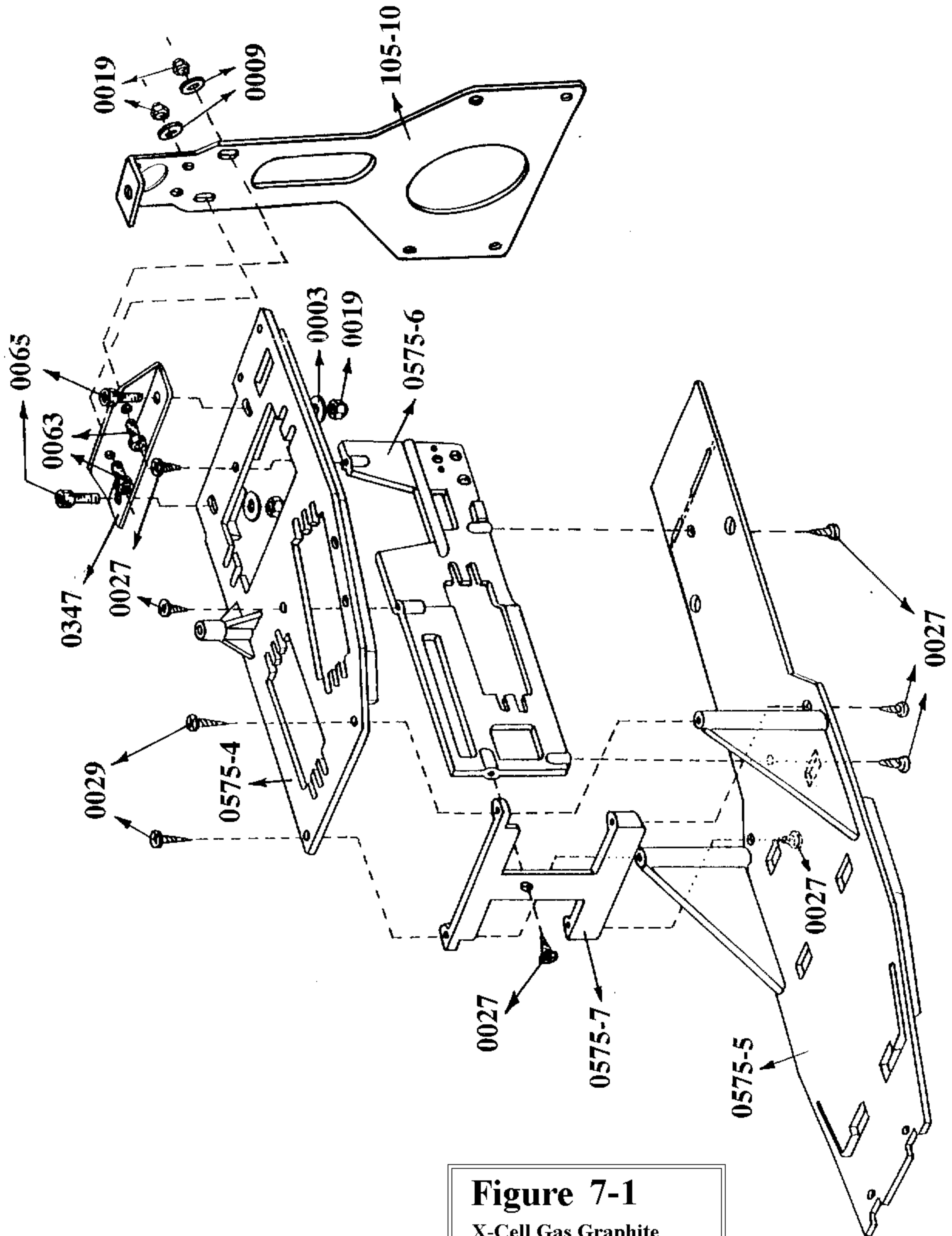

Figure 7-1
X-Cell Gas Graphite
<http://www.rchelibase.com>

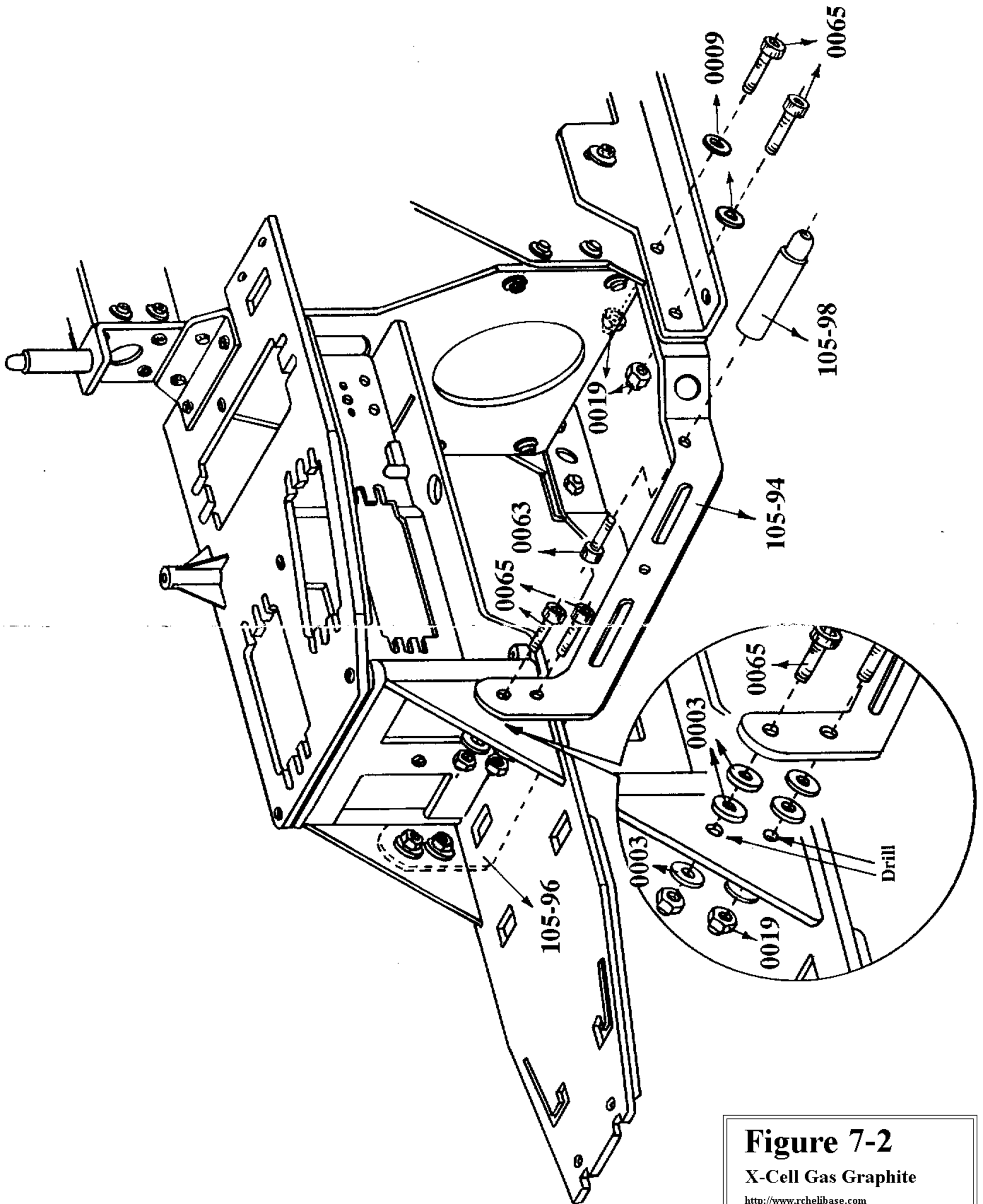

Figure 7-2
X-Cell Gas Graphite
<http://www.rchelibase.com>

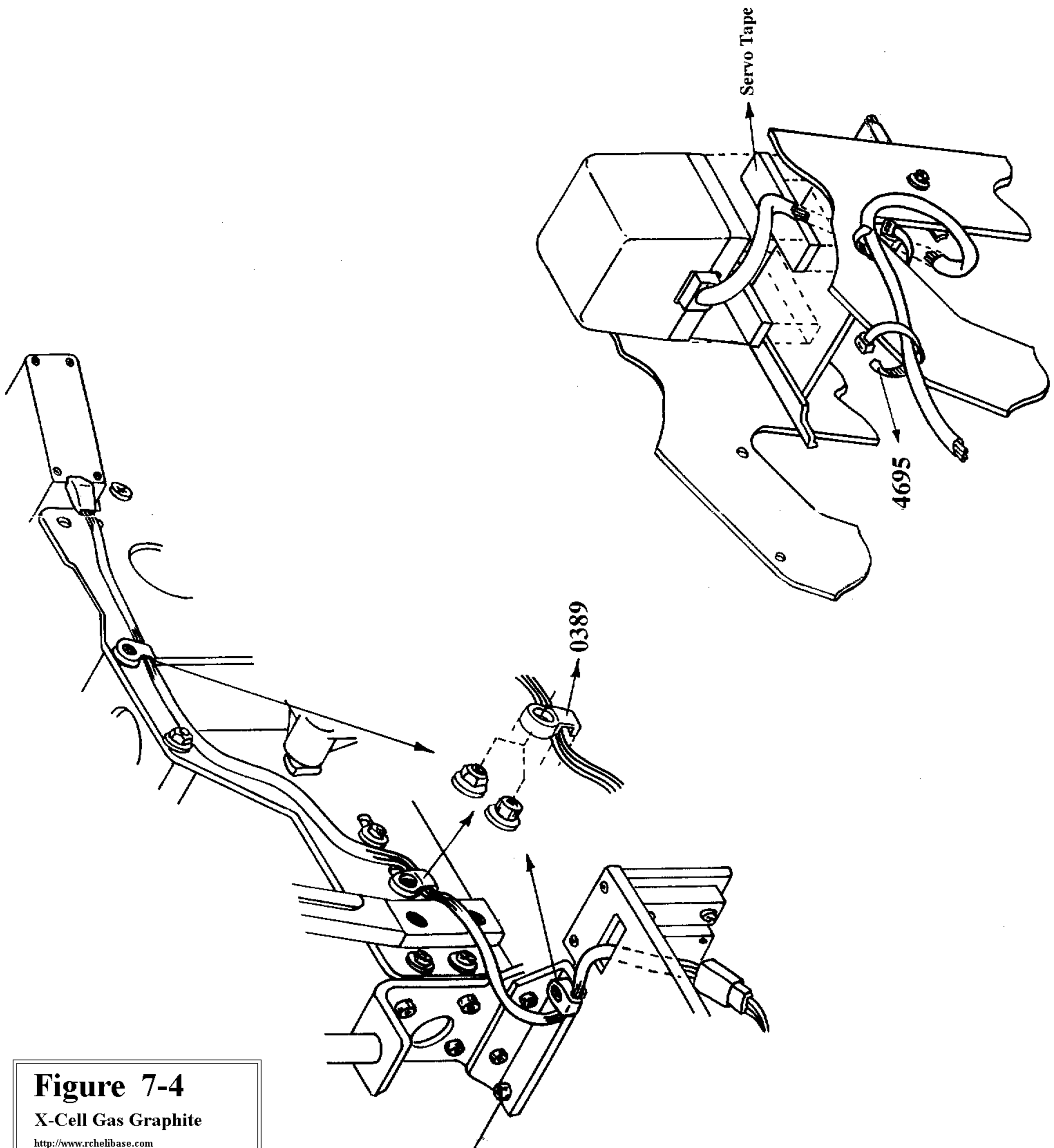
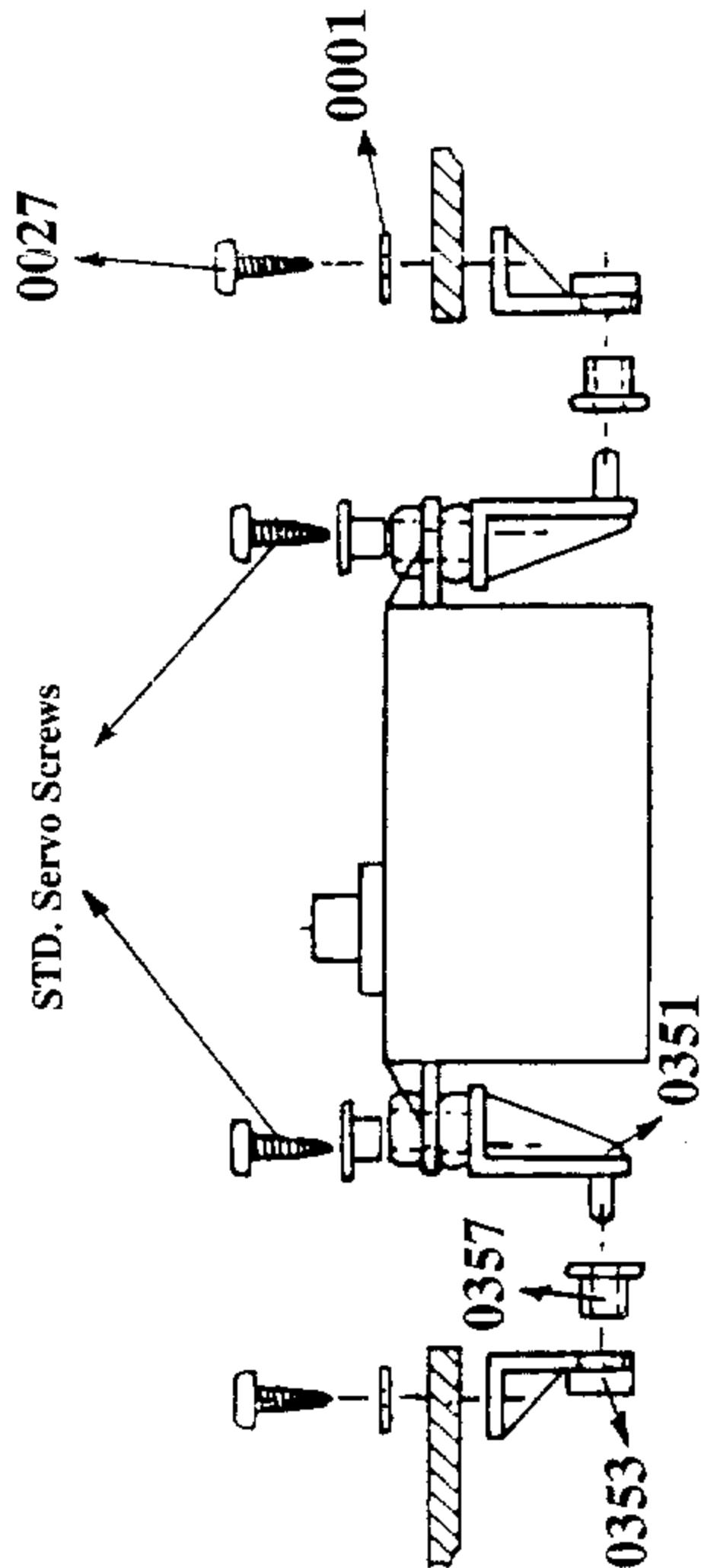
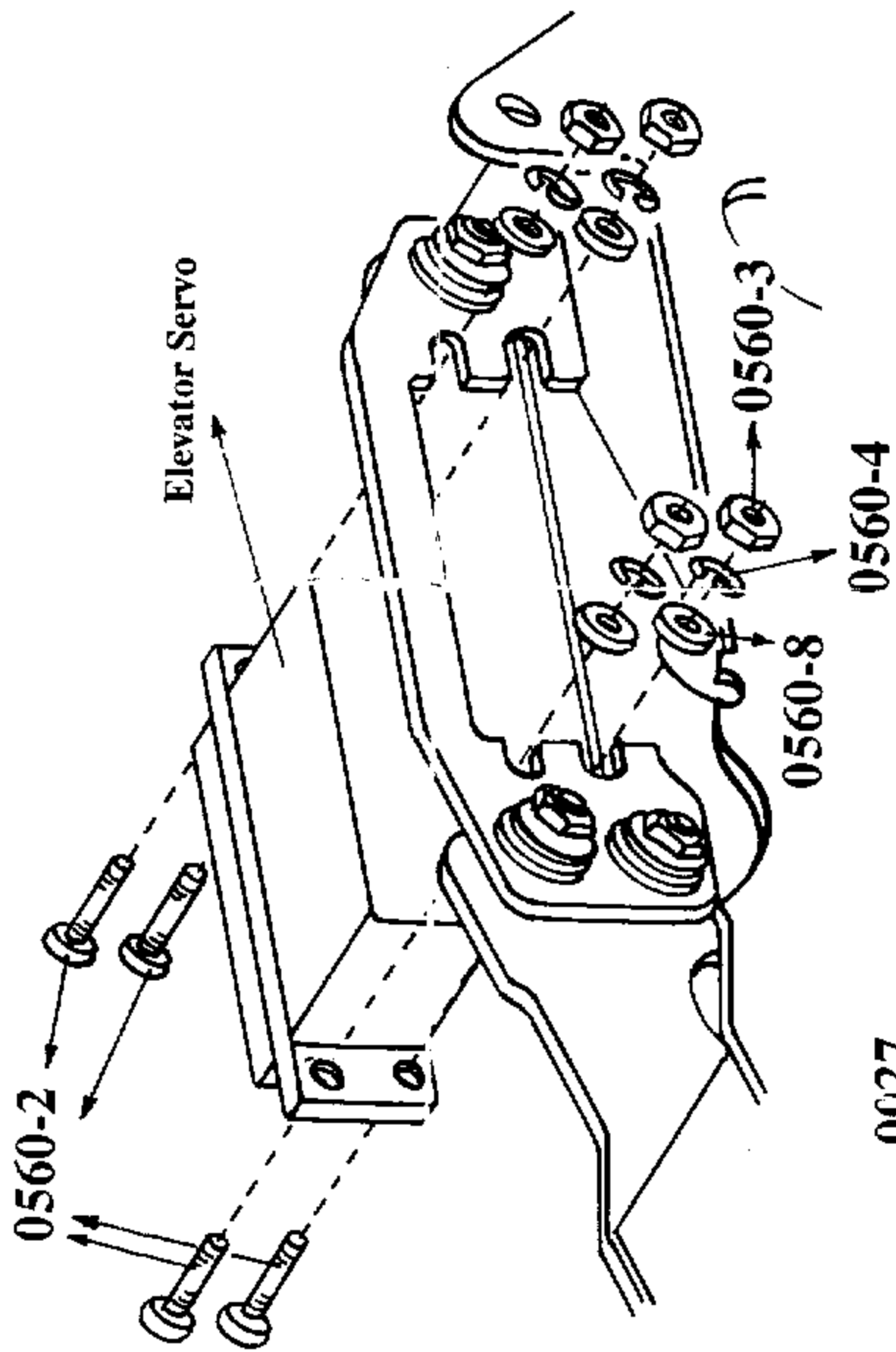

Figure 7-4

X-Cell Gas Graphite

<http://www.rchelibase.com>



Aileron Servo

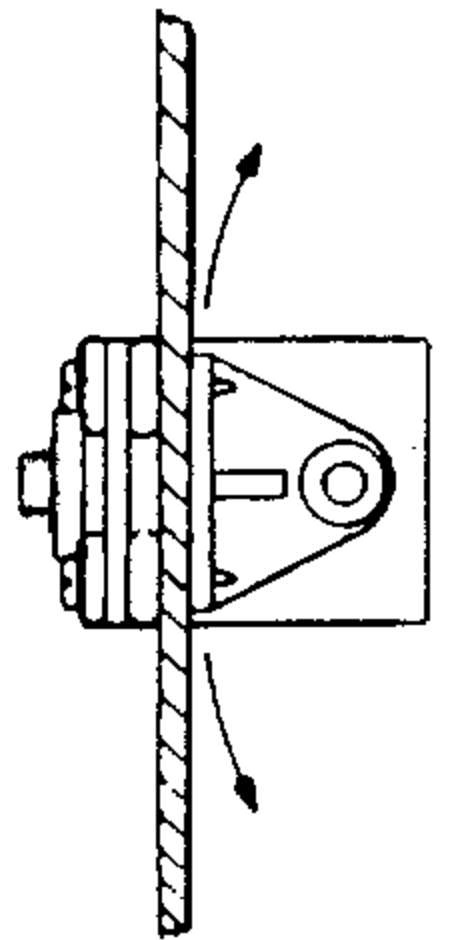

Figure 7-5
X-Cell Gas Graphite

<http://www.rchelibase.com>

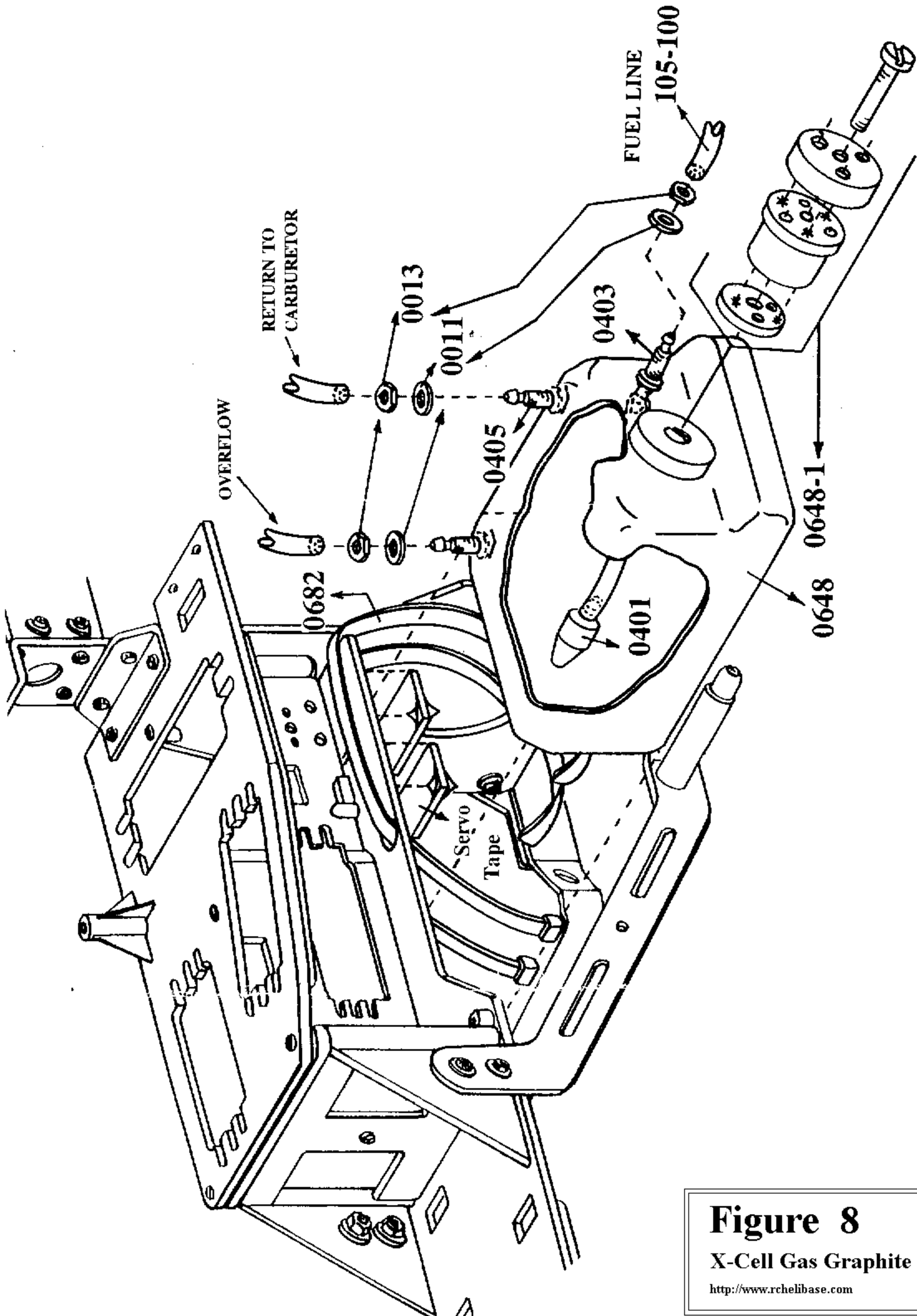

Figure 8
 X-Cell Gas Graphite
<http://www.rchelibase.com>

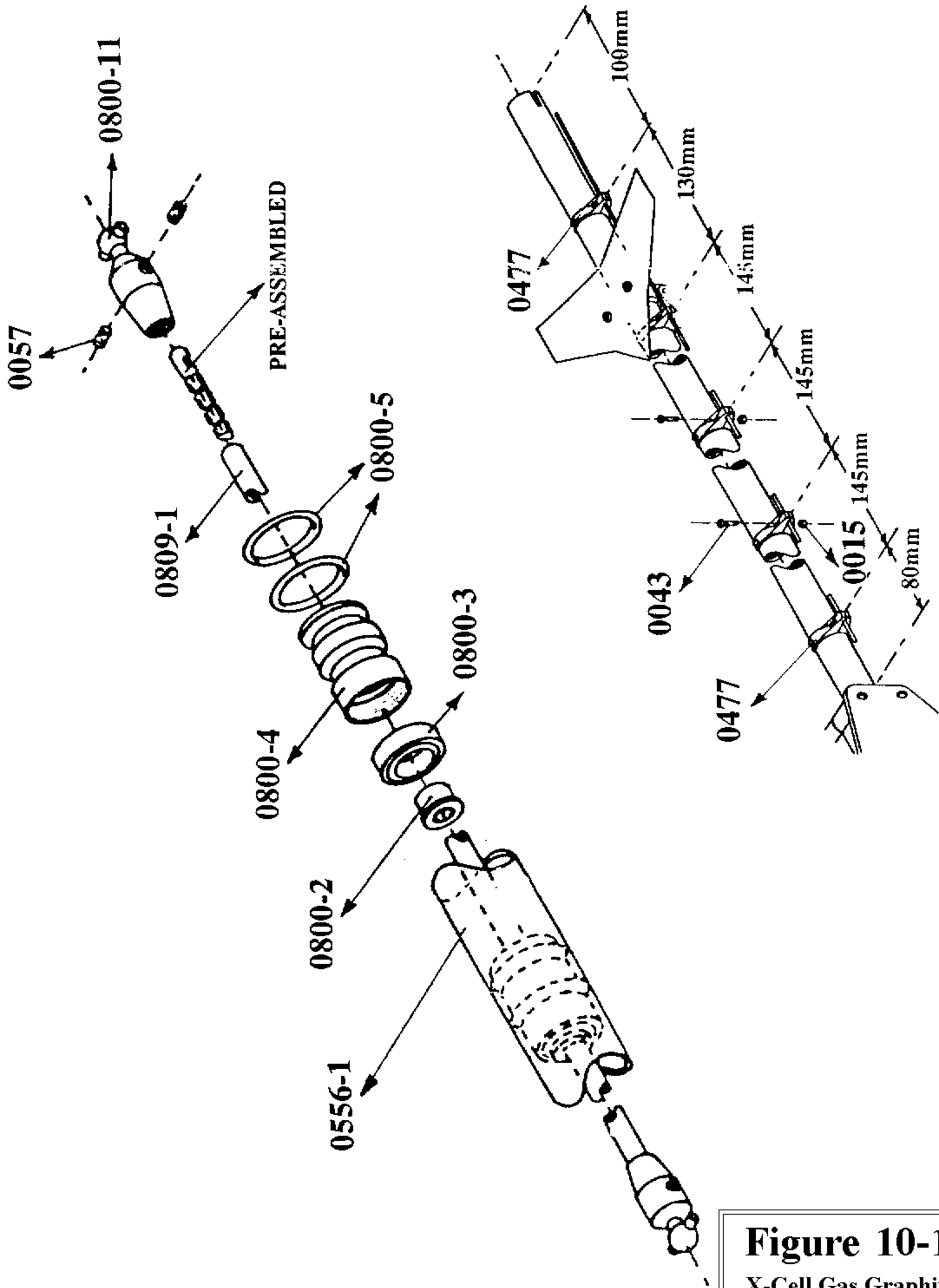

Figure 10-1

X-Cell Gas Graphite

<http://www.rchelibase.com>

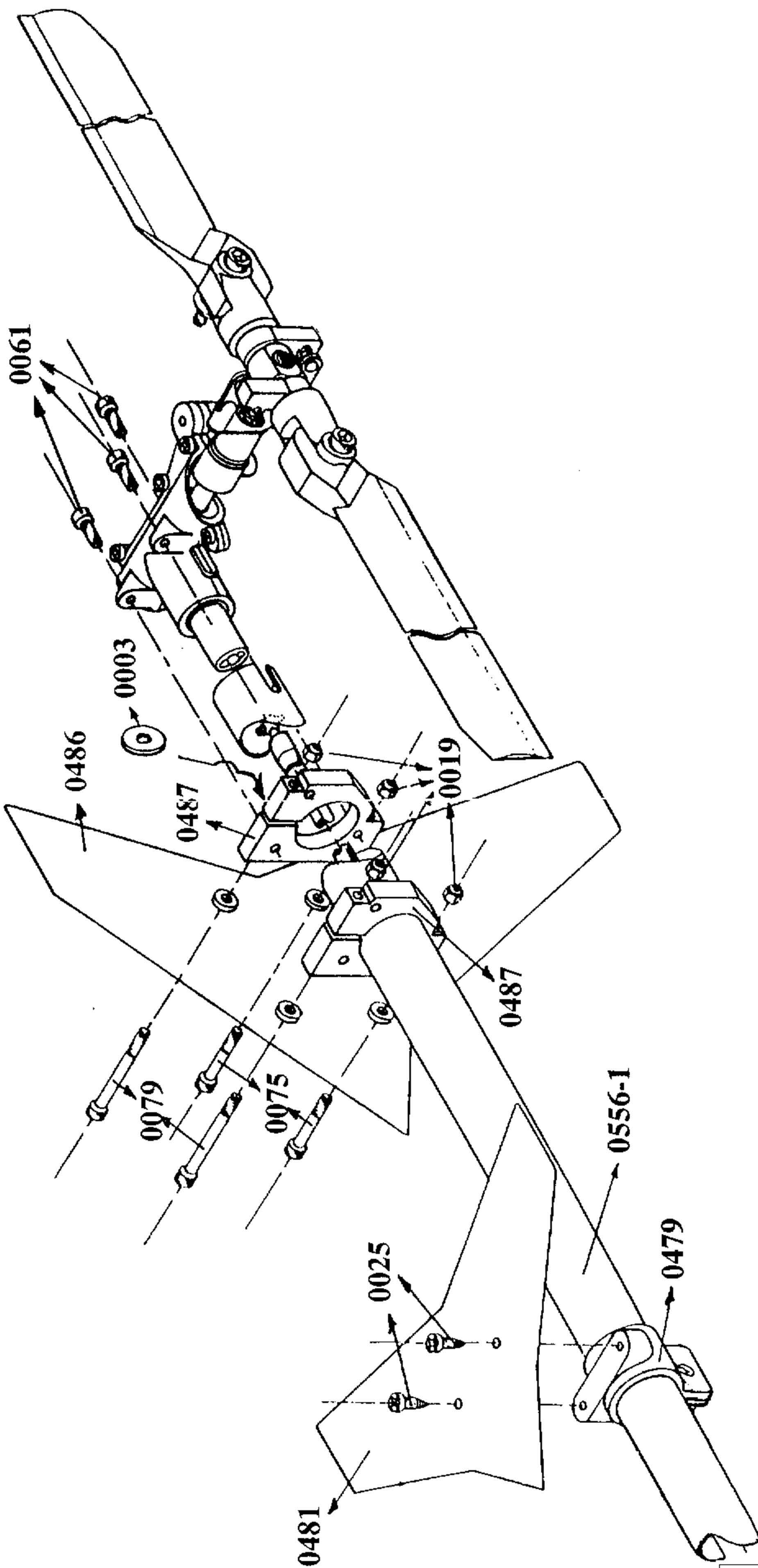

Figure 10-2
X-Cell Gas Graphite
<http://www.rchelibase.com>

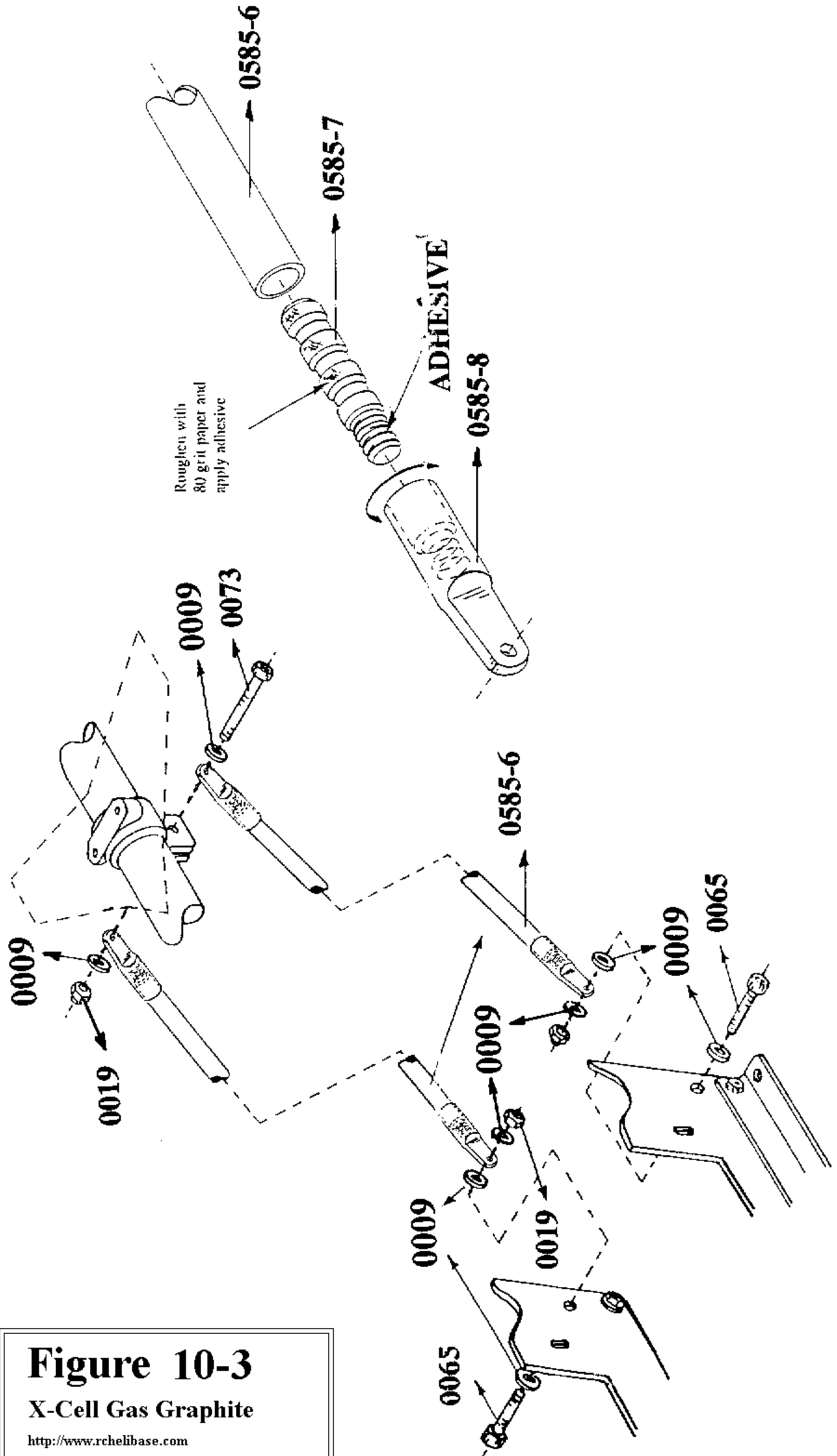
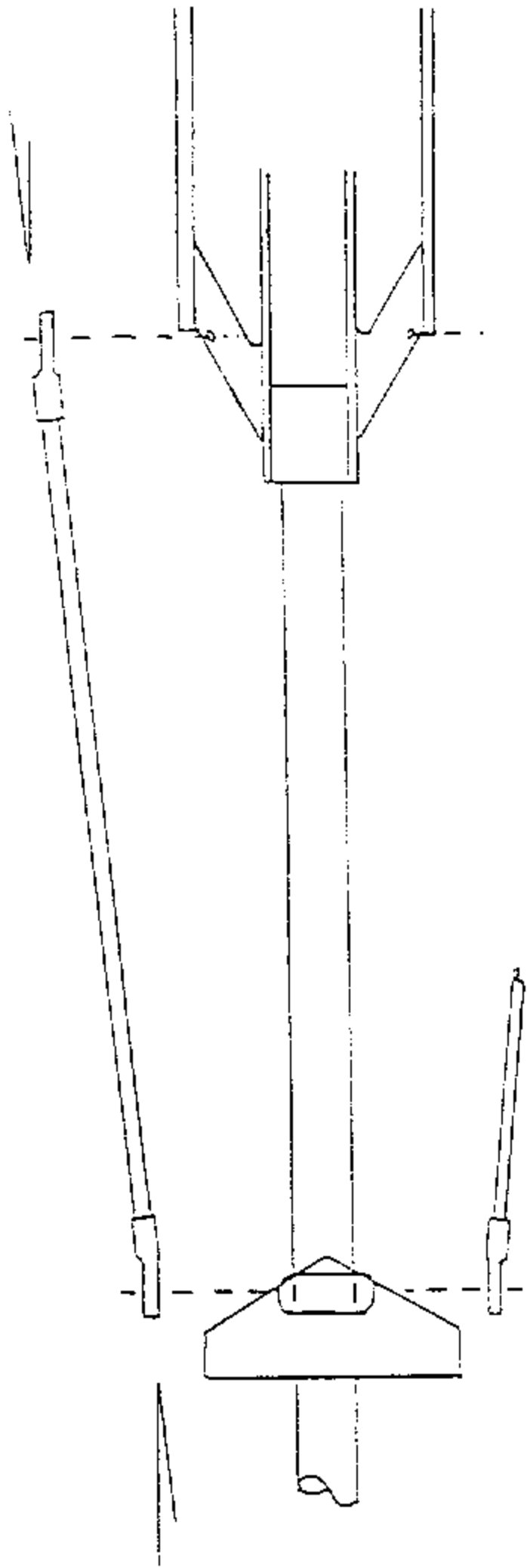

Figure 10-3
 X-Cell Gas Graphite
<http://www.rchelibase.com>

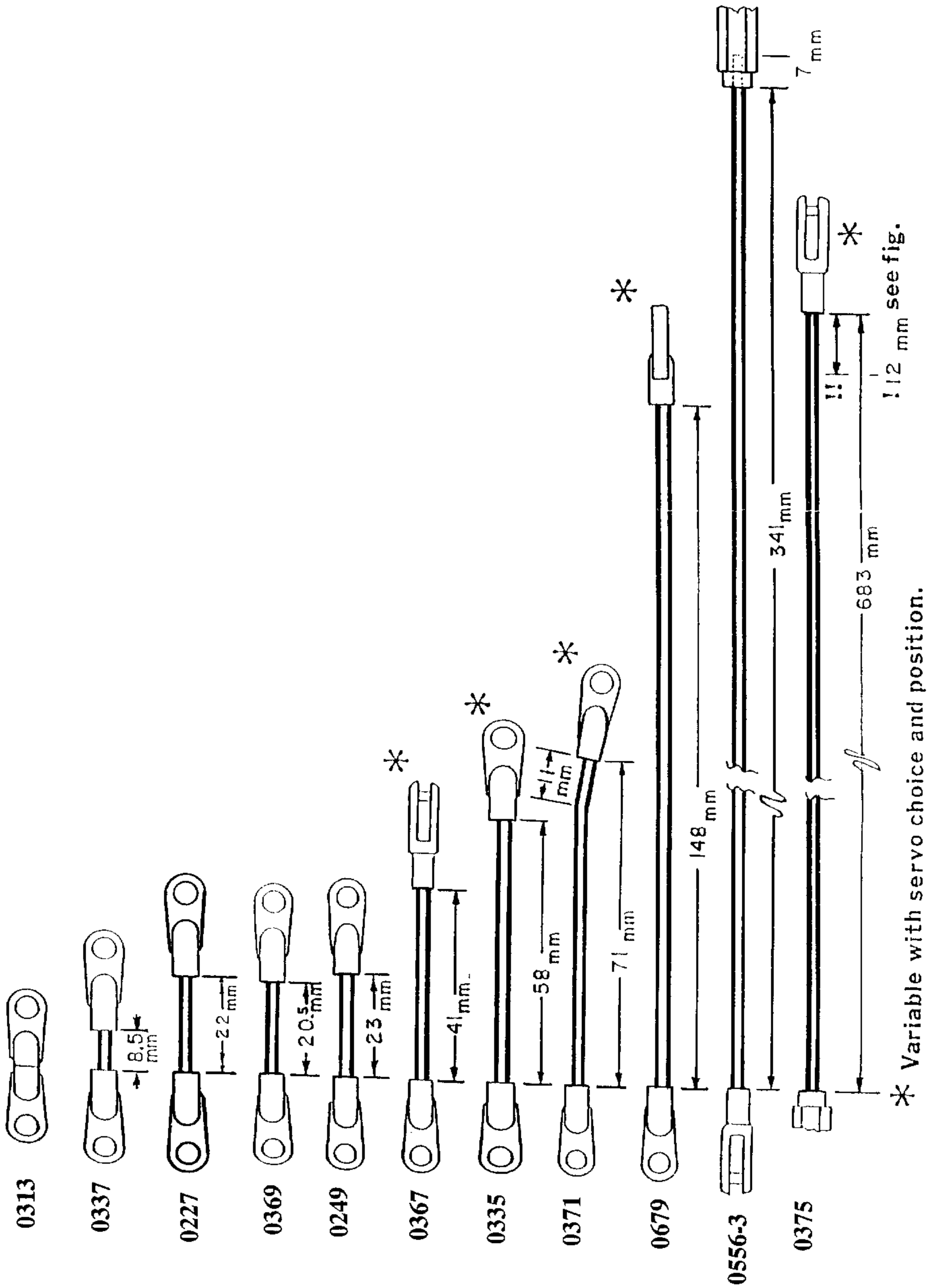

Figure 11-1
 X-Cell Gas Graphite
<http://www.rchelibase.com>

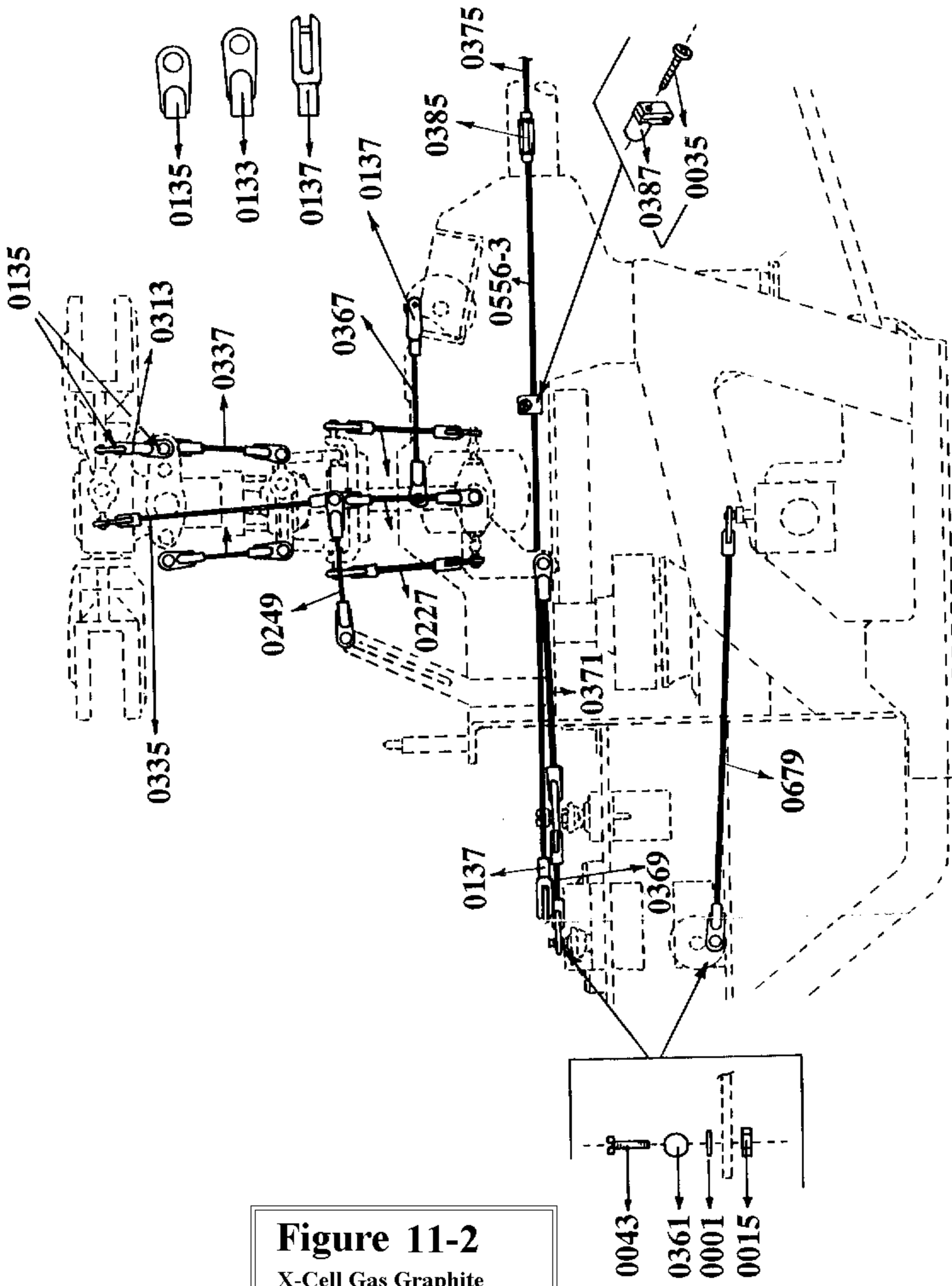

Figure 11-2
 X-Cell Gas Graphite
<http://www.rchelibase.com>

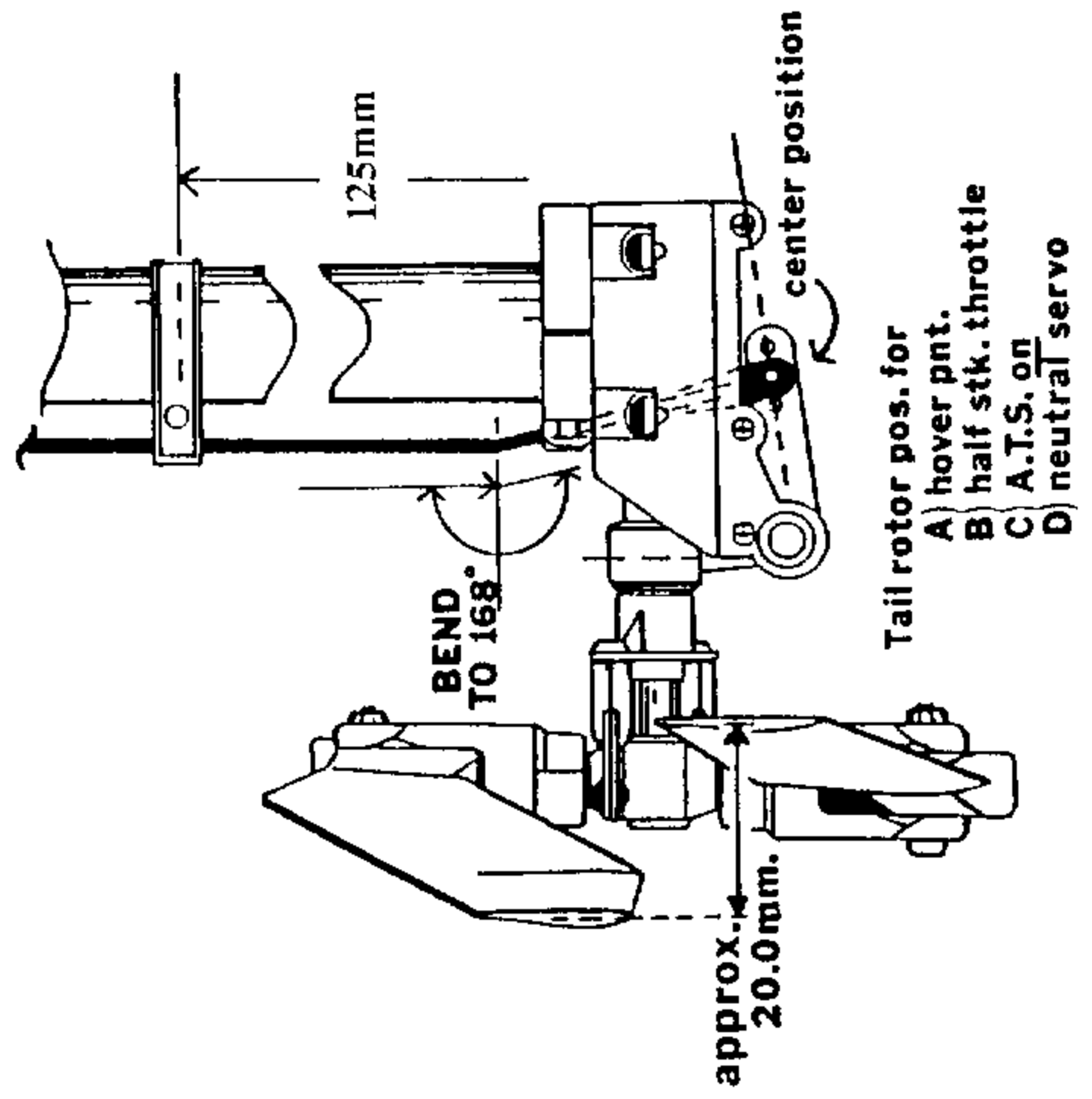
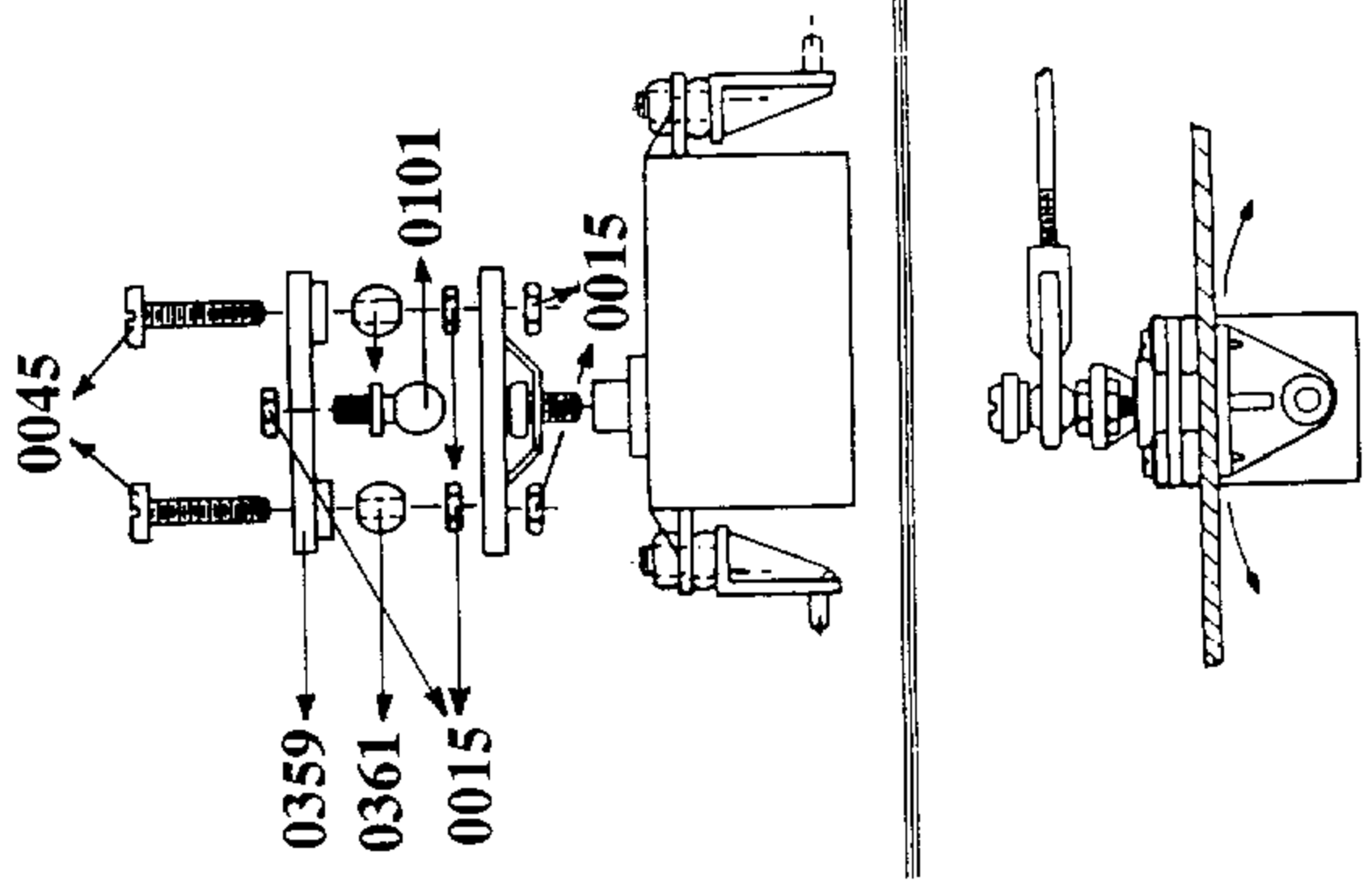
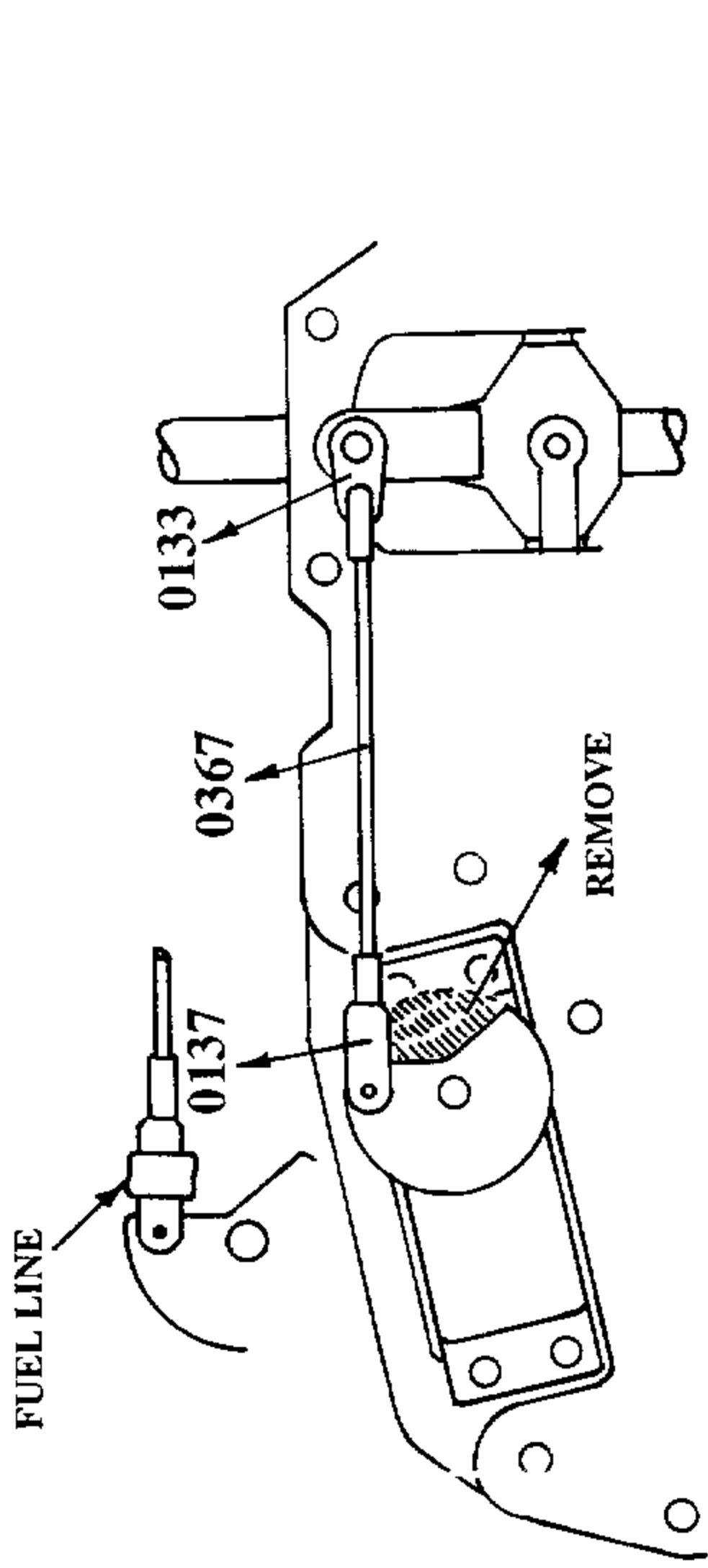

Figure 11-3
 X-Cell Gas Graphite
<http://www.rchelibase.com>

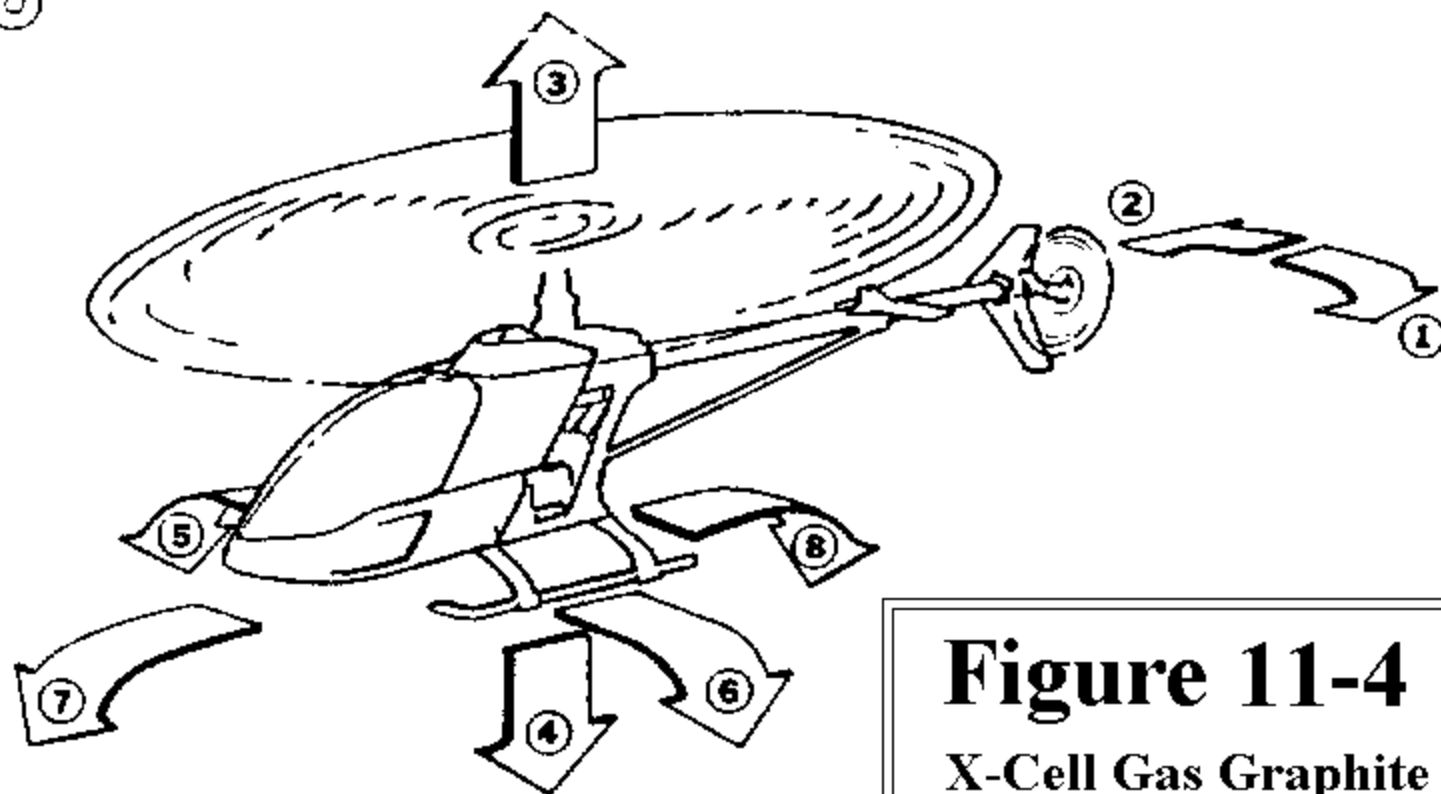
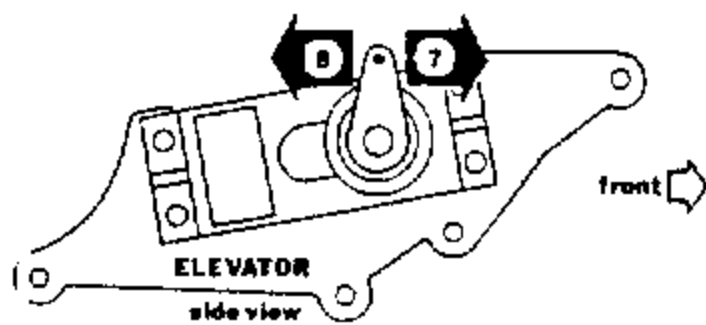
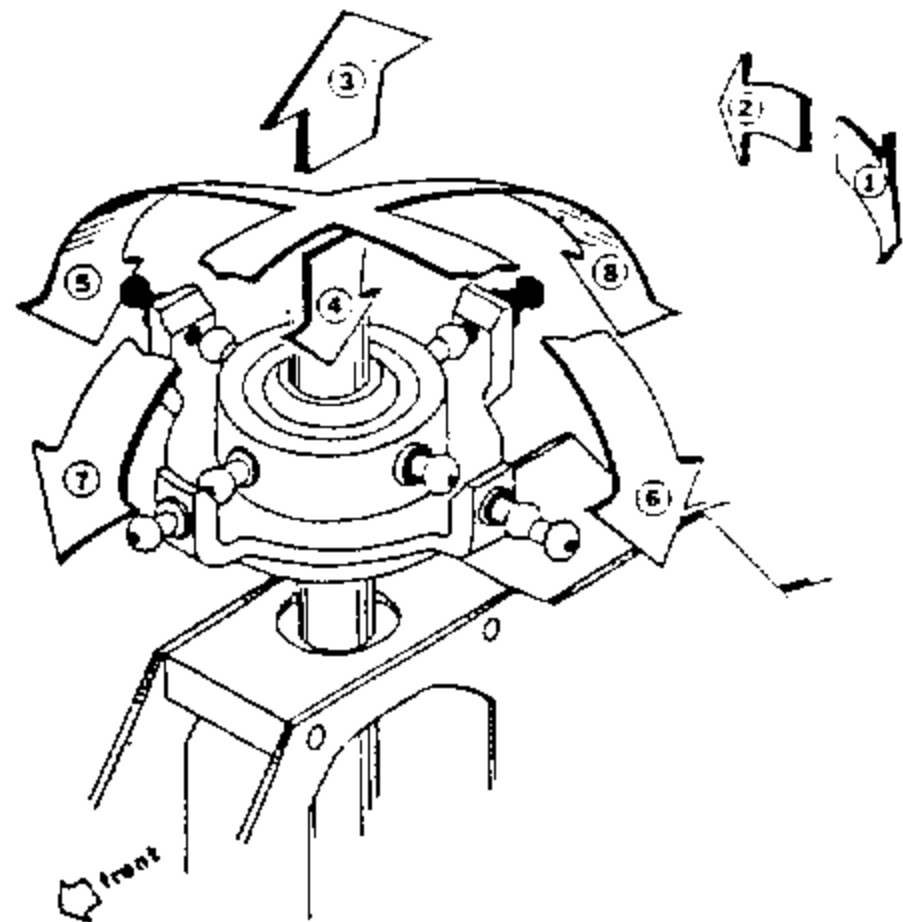
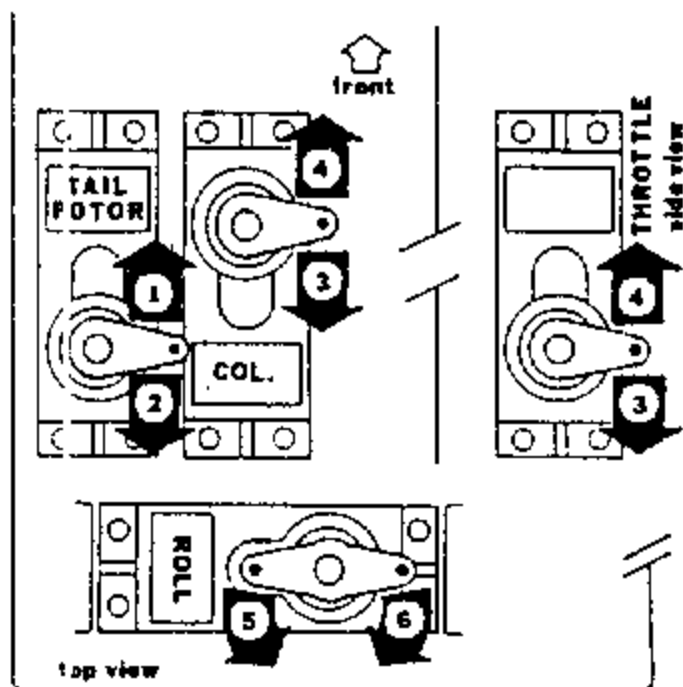
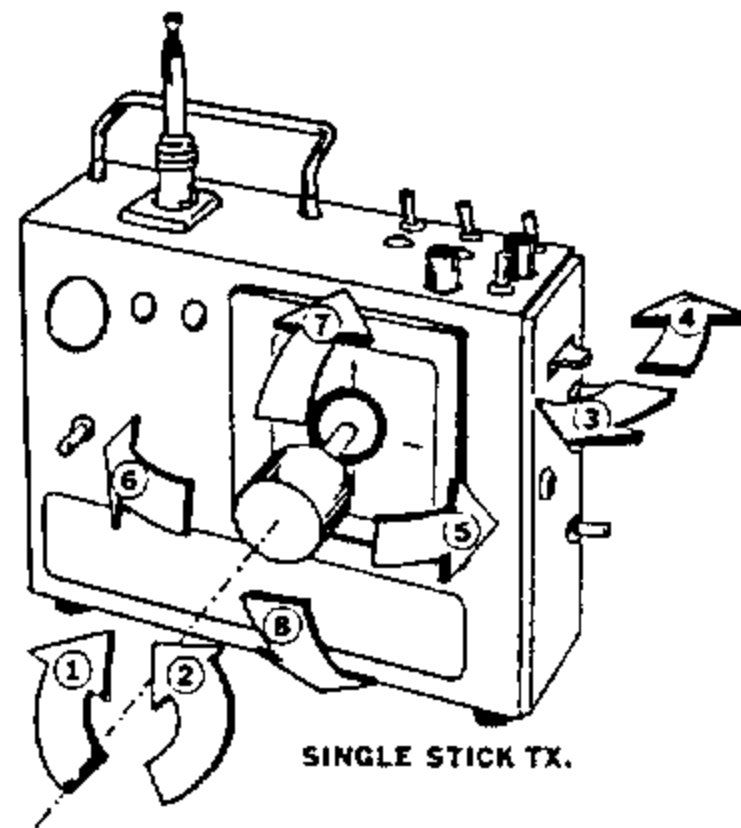
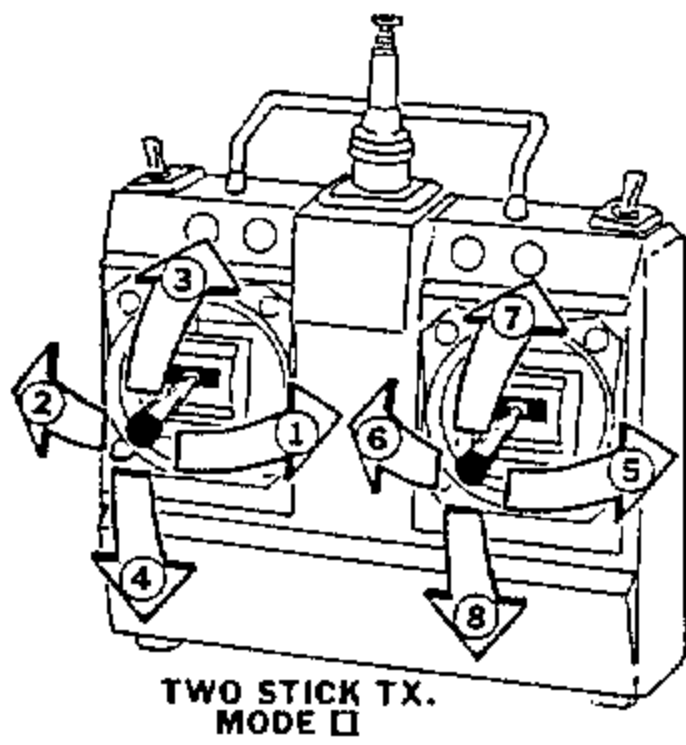

Figure 11-4

X-Cell Gas Graphite

<http://www.rcelibase.com>

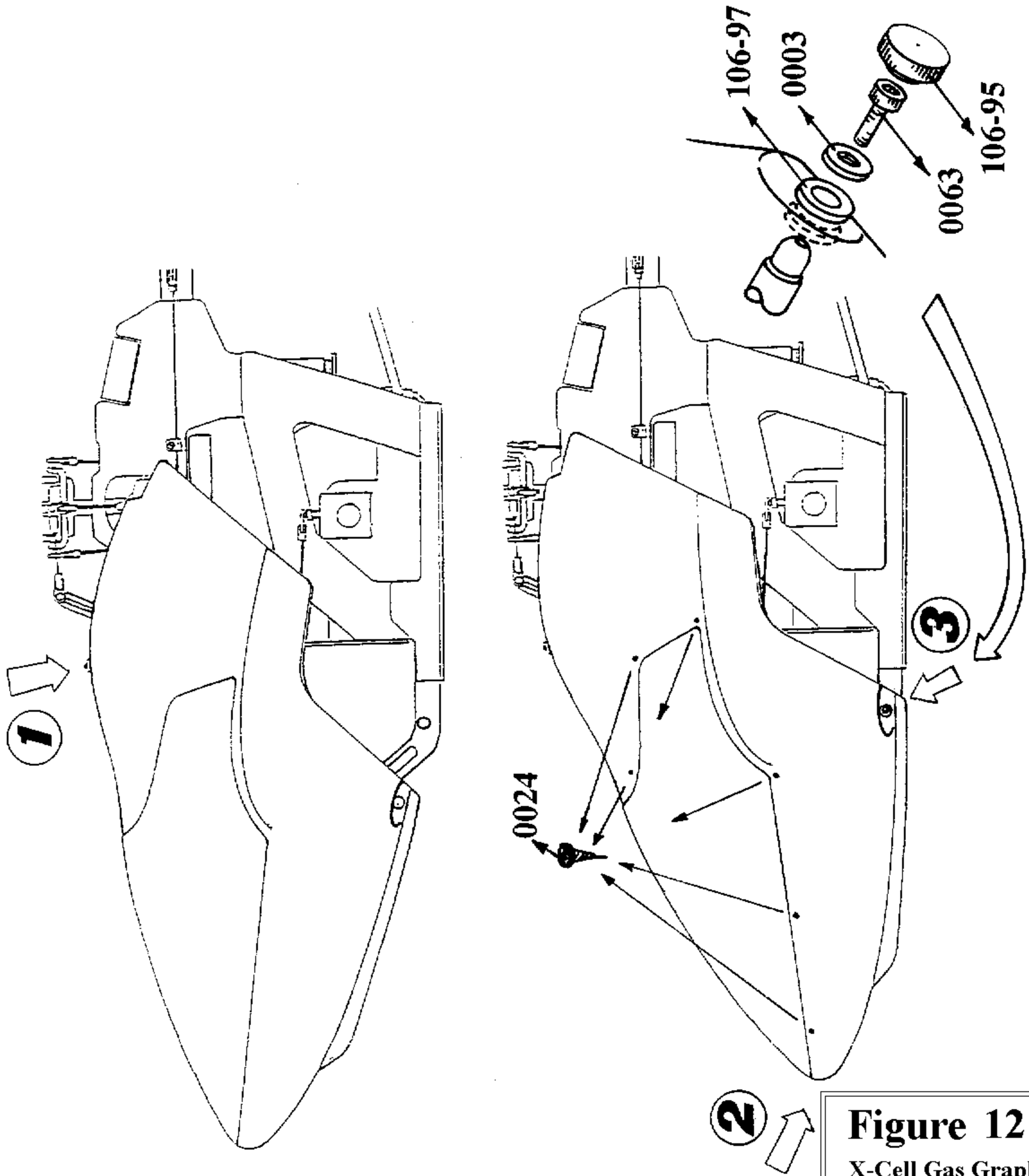

Figure 12
X-Cell Gas Graphite
<http://www.rchelibase.com>

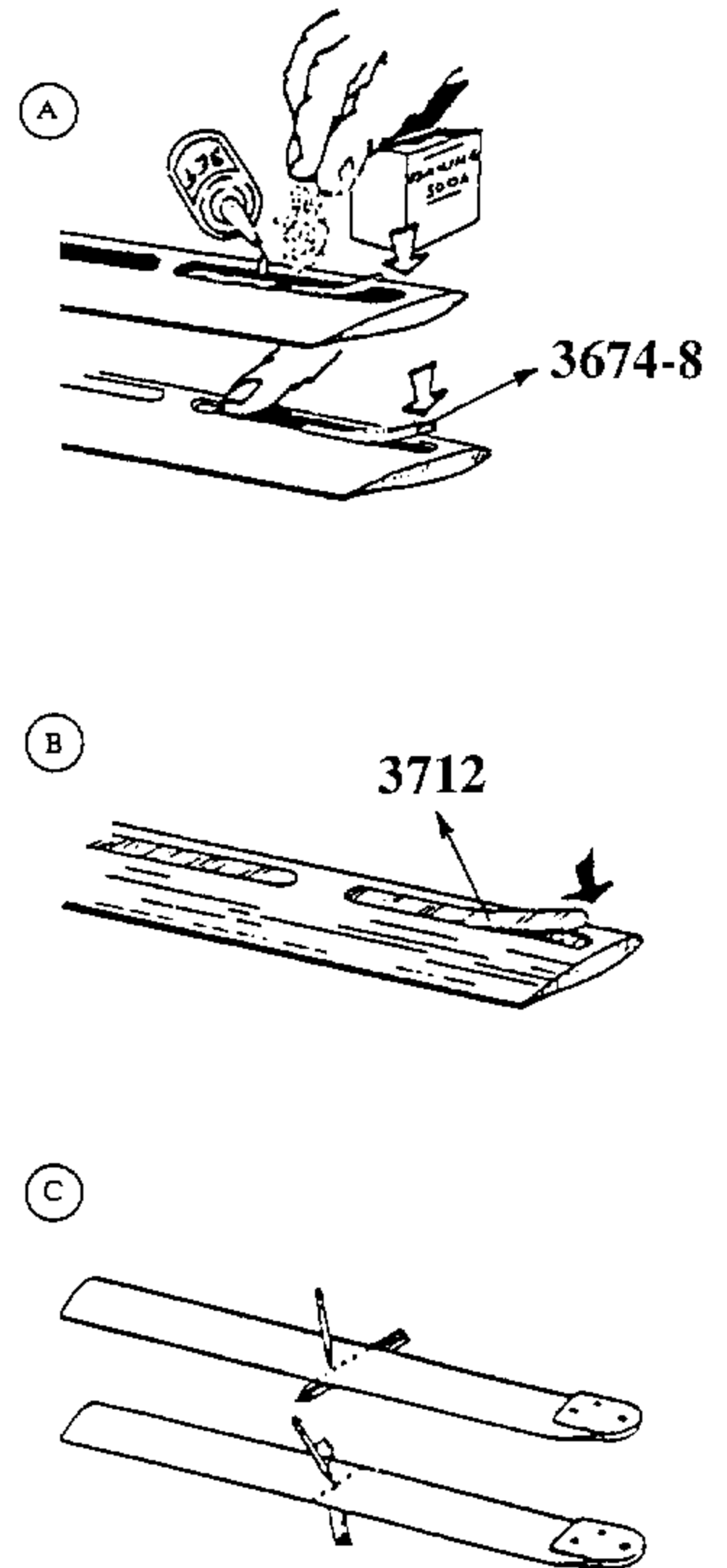
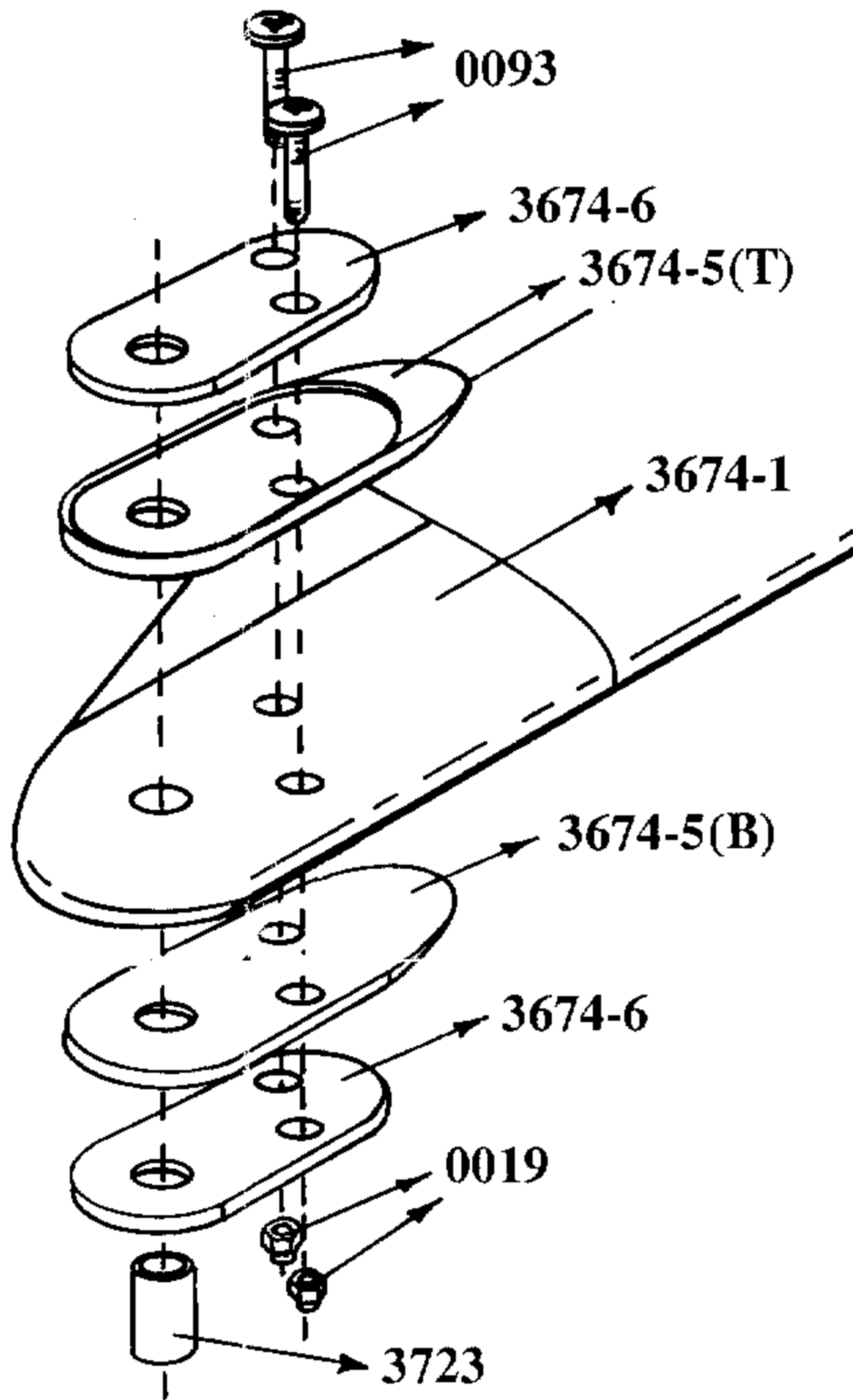

Figure 13-1

X-Cell Gas Graphite

<http://www.rchelibase.com>

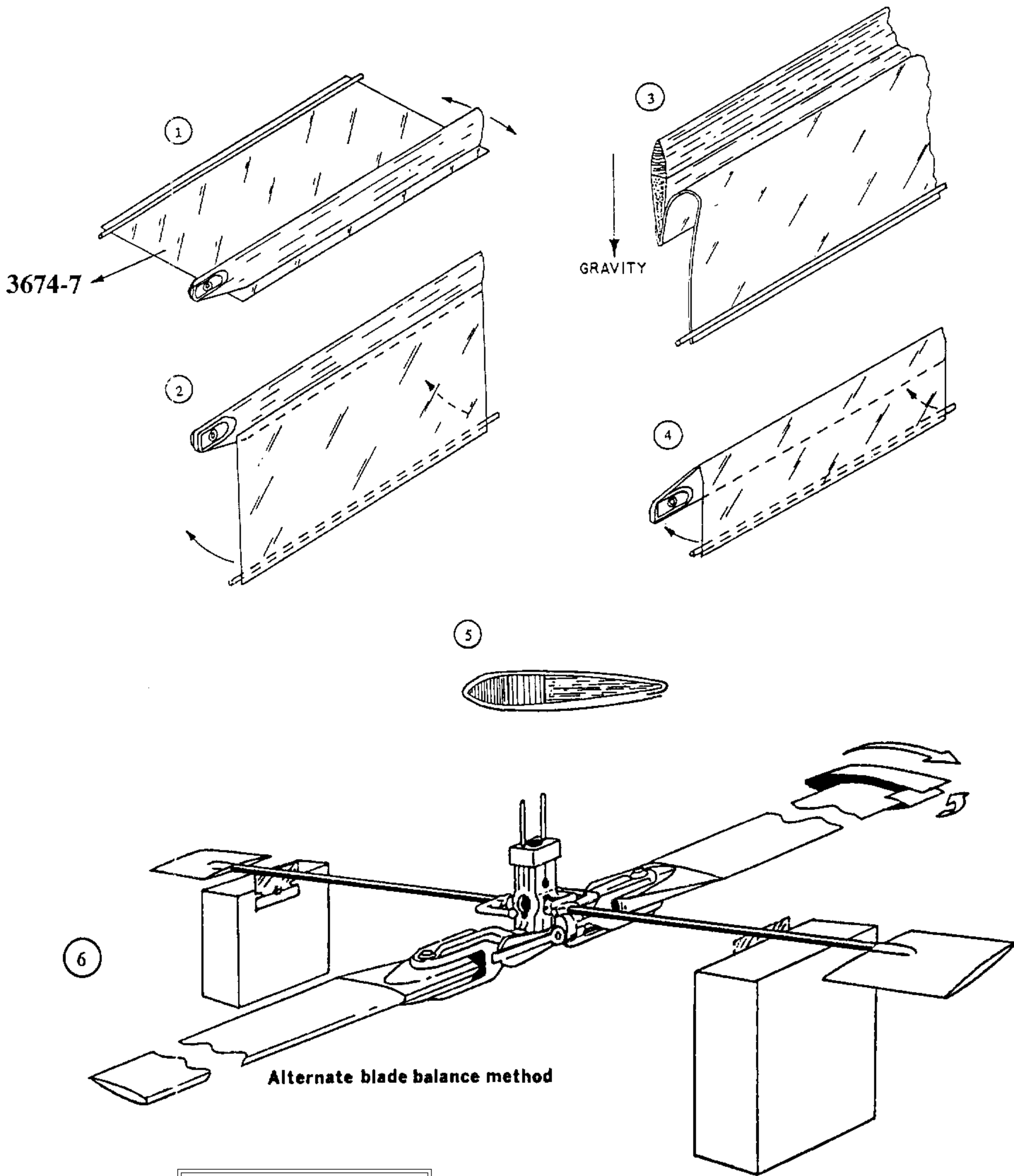

Figure 13-2
 X-Cell Gas Graphite
<http://www.rchelibase.com>